

Company: Joyoung International Trading Co.,Limited
Atten: Smiling
Mobile/WhatsApp:+86 18050035902
E-mail: info@htechplc.com
Website: <https://www.joyoungintl.com/>

ABB Drives

User's Manual

Digital I/O Extension Module RDIO-01

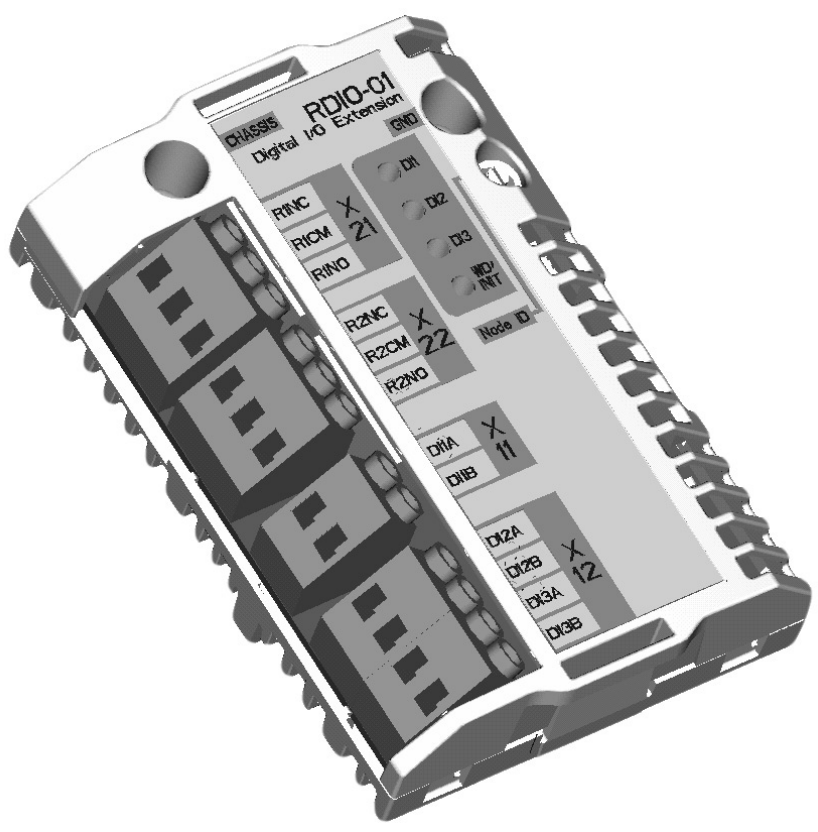

Digital I/O Extension Module
RDIO-01

User's Manual

3AFE 64485733 REV B EN

EFFECTIVE: 10.2.2003

Safety Instructions

Overview

This chapter states the general safety instructions that must be followed when installing and operating the RDIO-01 Digital I/O Extension module.

The material in this chapter must be studied before attempting any work on, or with, the unit.

In addition to the safety instructions given below, read the complete safety instructions of the specific drive you are working on.

General safety instructions



WARNING! All electrical installation and maintenance work on the drive should be carried out by qualified electricians only.

The drive and adjoining equipment must be properly earthed.

Do not attempt any work on a powered drive. After switching off the mains, always allow the intermediate circuit capacitors 5 minutes to discharge before working on the frequency converter, the motor or the motor cable. It is good practice to check (with a voltage indicating instrument) that the drive is in fact discharged before beginning work.

The motor cable terminals of the drive are at a dangerously high voltage when mains power is applied, regardless of motor operation.

There can be dangerous voltages inside the drive from external control circuits even when the drive mains power is shut off. Exercise appropriate care when working on the unit. Neglecting these instructions can cause physical injury or death.

Safety Instructions

Table of contents

Safety Instructions

| | |
|---------------------------------------|-------|
| Overview | 1-iii |
| General safety instructions | 1-iii |

Table of contents

Chapter 1 – Introduction

| | |
|-------------------------------------|-----|
| Intended audience | 1-1 |
| Before you start | 1-1 |
| What this manual contains | 1-2 |

Chapter 2 – Overview

| | |
|----------------------------------------------|-----|
| Overview | 2-1 |
| The RDIO-01 module | 2-1 |
| Module layout | 2-2 |
| Delivery check | 2-3 |
| Compatibility | 2-3 |
| Warranty and liability information | 2-3 |

Chapter 3 – Installation

| | |
|-------------------------------------------------------------|-----|
| Mounting | 3-1 |
| Removing and refitting the cover of the enclosure | 3-2 |
| Switches | 3-2 |
| Digital input hardware filter suppression | 3-3 |
| Terminal designations | 3-4 |
| Wiring | 3-5 |
| Digital input wiring examples | 3-5 |
| Node ID selection | 3-6 |
| Programming | 3-6 |

Table of contents

Chapter 4 – Fault tracing

| | |
|-------------------------------------------|-----|
| Diagnostic LEDs | 4-1 |
| Option slot installation | 4-1 |
| I/O Module Adapter installation | 4-1 |

Appendix A – Technical data

Chapter 1 – Introduction

Intended audience

The manual is intended for the people who are responsible for commissioning and using an RDIO-01 Digital I/O Extension module with the ACS 800 drive. The reader is expected to have a basic knowledge of electrical fundamentals, electrical wiring practices and how to operate the drive.

Before you start

It is assumed that the drive is installed and ready to operate before starting the installation of the extension module.

In addition to conventional installation tools, have the drive manuals available during the installation as they contain important information not included in this manual. The drive manuals are referred to at various points of this document.

What this manual contains

This manual contains information on the wiring, configuration and use of the RDIO-01 module.

Safety instructions are featured in the first few pages of this manual.

Chapter 2 – Overview contains a short description of the RDIO-01 Digital I/O Extension module, a delivery checklist and warranty information.

Chapter 3 – Installation contains instructions for module hardware settings, mounting and cabling.

Chapter 4 – Fault tracing explains fault tracing and the LED indications of the RDIO-01 module.

Appendix A contains technical data.

Chapter 2 – Overview

Overview

This chapter contains a short description of the Digital I/O Extension module, a delivery checklist and warranty information.

The RDIO-01 module

The Digital I/O Extension module (RDIO) offers three digital inputs (24...250 V DC or 110...230 V AC) and two relay outputs (1250 VA/250 V AC or 5 A/24 V DC). The isolation voltage between the digital inputs, digital outputs and power supply is 2.5 kV (1.5 kV between DI2 and DI3).



WARNING! According to international standards, applying voltages below 50 V (DC or AC) and above 150 V (AC or DC) simultaneously to the digital inputs and/or outputs of the RDIO-01 is not allowed. Additionally, only voltages of the same nominal level should be applied simultaneously to digital inputs DI2 and DI3 due to reduced isolation voltage.

Module layout

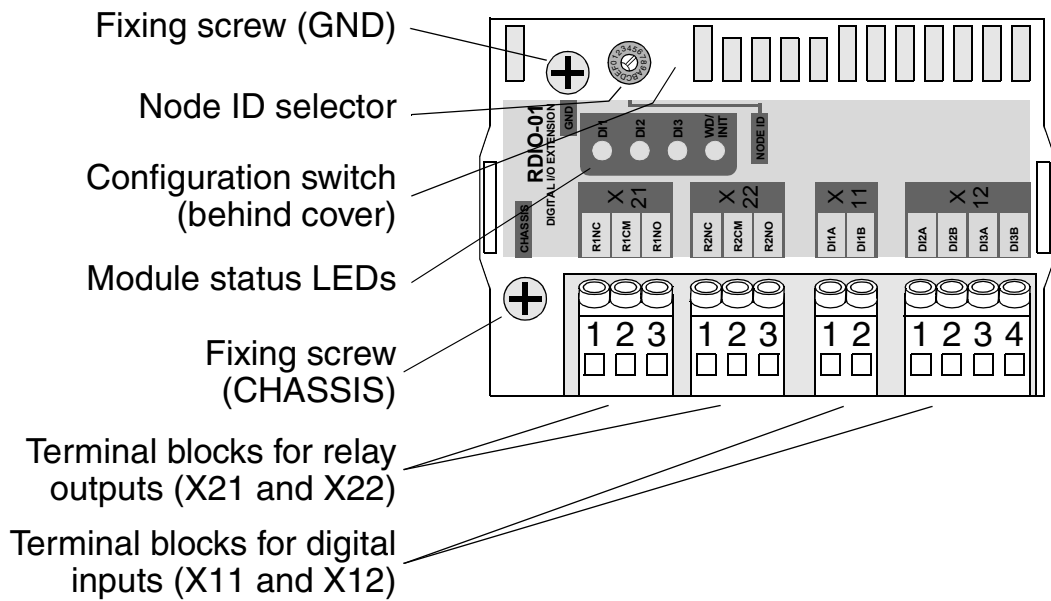

Delivery check The option package contains:

- RDIO-01 module
- Two screws (M3×8 mm)
- This manual.

Compatibility The RDIO-01 is compatible with the ACS 800 Standard Application Program version ASXR7000 or later.

**Warranty and
liability
information**

The warranty for your ABB drive and options covers manufacturing defects. The manufacturer carries no responsibility for damage due to transport or unpacking.

In no event and under no circumstances shall the manufacturer be liable for damages and failures due to misuse, abuse, improper installation, or abnormal conditions of temperature, dust, or corrosives, or failures due to operation above rated capacities. Nor shall the manufacturer ever be liable for consequential and incidental damages.

The period of manufacturer's warranty is 12 months, and not more than 18 months, from the date of delivery. Extended warranty may be available with certified start-up. Contact your local distributor for details.

Your local ABB Drives company or distributor may have a different warranty period, which is specified in their sales terms, conditions, and warranty terms.

If you have any questions concerning your ABB drive, contact your local distributor or ABB Drives office.

The technical data and specifications are valid at the time of printing. ABB reserves the right to subsequent alterations.

Chapter 2 – Overview

Chapter 3 – Installation



WARNING! Follow the safety instructions given in this guide and in the *ACS 800 Hardware Manual*.

Mounting

The RDIO-01 is to be inserted into the position marked SLOT 1 or SLOT 2 on the drive. The module is held in place with plastic retaining clips and two screws. The screws also provide the earthing of the I/O cable shield connected to the module, and interconnect the GND signals of the module and the RMIO board.

On installation of the module, the signal and power connection to the drive is automatically made through a 38-pin connector.

Mounting procedure:

1. Insert the module carefully into SLOT 1 or SLOT 2 on the RMIO board until the retaining clips lock the module into position.
2. Fasten the two screws (included) to the stand-offs.
3. Remove the cover of the module enclosure – directions are given below.
4. Set the configuration DIP switches of the module to the required position and refit the cover.

Note: Correct installation of the screws is essential for fulfilling the EMC requirements and for proper operation of the module.

Removing and refitting the cover of the enclosure

To choose operating mode and input signal type, the cover of the module enclosure must be removed. This can be done by carefully bending the two cover retaining clips with a small screwdriver (see Figure 3-1) and lifting the cover off.

Refit the cover by pushing it back into its place until the retaining clips lock it into position.

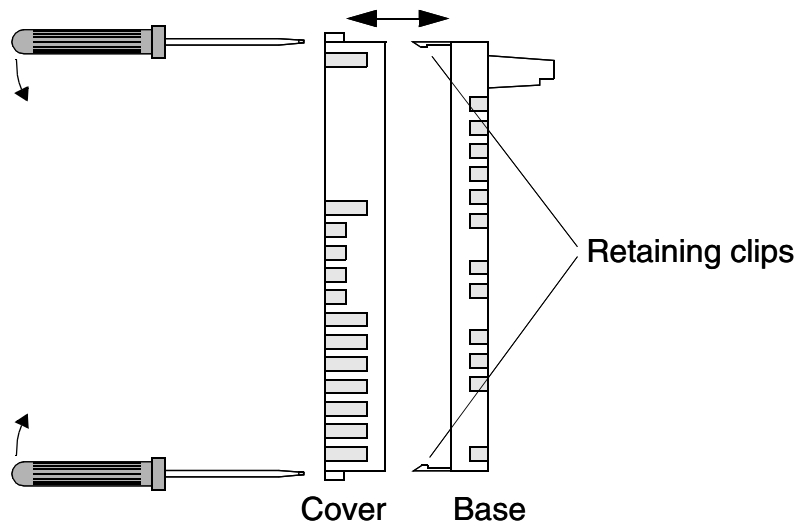

Figure 3-1 Removing and refitting the cover

Switches

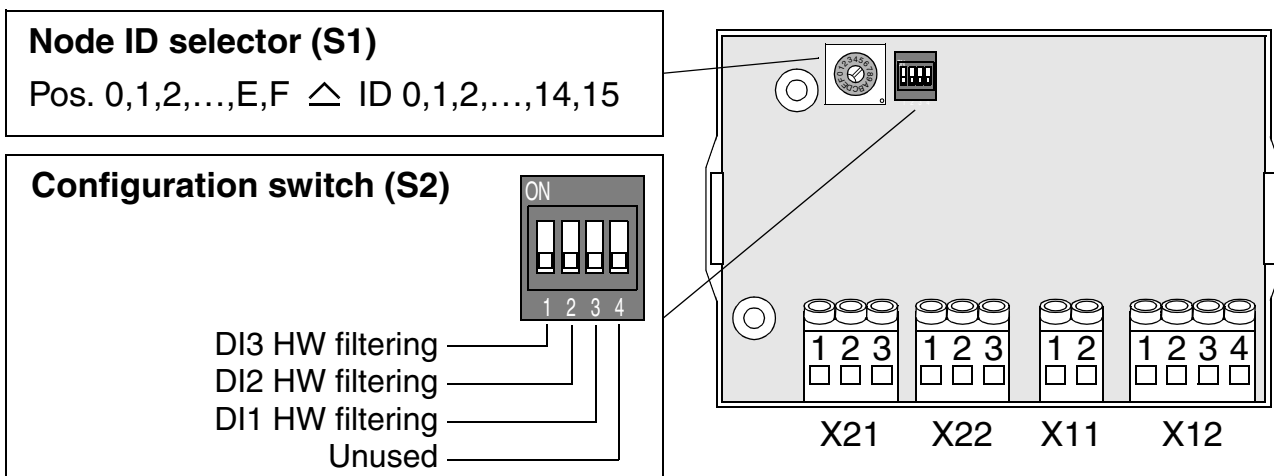
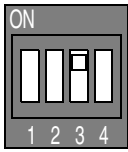
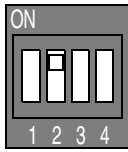
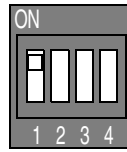
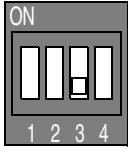
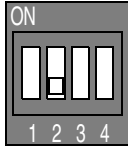
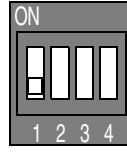

Figure 3-2 Top view of the module, cover removed

Digital input hardware filter suppression

For faster input signal detection with a DC signal, the hardware filter of the digital input in question can be disabled using the configuration DIP switch (S2) on the circuit board of the module. Disabling the hardware filtering will however reduce the noise immunity of the input.

| Hardware Filtering | DIP switch settings | | |
|--------------------|------------------------------------------------------------------------------------|--------------------------------------------------------------------------------------|--------------------------------------------------------------------------------------|
| | Digital input DI1 | Digital input DI2 | Digital input DI3 |
| Enabled (Default) |  |  |  |
| Disabled |  |  |  |

Note: Always have the hardware filtering enabled with an AC input signal.

Note: Actuator no. 4 is unused.

Terminal designations

| Marking | | Description | |
|------------|------|-------------------|-------------------------------------------------------------------------------------------------------------------------------------------------------------------------------------------------------------------------------------------------------------------------------------------------------|
| X11 | | | |
| 1 | DI1A | Digital input DI1 | DC signal: 24 to 250 V, 4...10 mA Signal levels: “1” > 12 V; “0” < 8 V AC signal: 110 to 230 V ±10%, max. 4 mA Signal levels: “1” > 40 V; “0” < 20 V |
| 2 | DI1B | | |
| X12 | | | |
| 1 | DI2A | Digital input DI2 | DI1: Galvanically isolated from other digital inputs, relay outputs and power supply (2.5 kV AC, 1 min) DI2 and DI3: Galvanically isolated as a group from DI1, relay outputs and power supply (2.5 kV AC, 1 min). Galvanically isolated from each other (1.5 kV AC, 1 min) |
| 2 | DI2B | | |
| 3 | DI3A | Digital input DI3 | |
| 4 | DI3B | | |

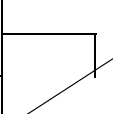
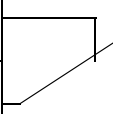
| Marking | | Description | |
|------------|------|-------------------------------------------------------------------------------------|---------------------------------------------------------------------------------------------------------------------------------------------------------------------------------------------------|
| X21 | | | |
| 1 | R1NC |  | Relay outputs RO1 and RO2: Max. continuous current: 2 A rms Switching capability: 8 A (24 V DC, resistive load) 0.4 A (120 V DC, resistive load) 2000 VA (250 V AC) |
| 2 | R1CM | | |
| 3 | R1NO | | |
| X22 | | | |
| 1 | R2NC |  | Galvanically isolated from each other, digital inputs and power supply (2.5 kV AC, 1 min) |
| 2 | R2CM | | |
| 3 | R2NO | | |

Wiring

0.5 to 1.5 mm² twisted pair unshielded cable with an appropriate voltage rating should be used for digital signals.



WARNING! According to international standards, applying voltages below 50 V (DC or AC) and above 150 V (AC or DC) simultaneously to the digital inputs and/or outputs of the RDIO-01 is not allowed. Additionally, only voltages of the same nominal level should be applied simultaneously to digital inputs DI2 and DI3 due to reduced isolation voltage.

Note: Do not route signal cables parallel to power cables.

Digital input wiring examples

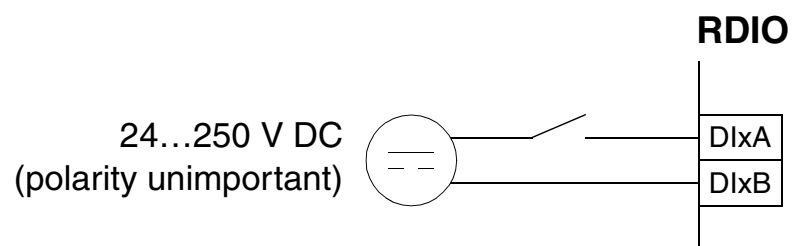
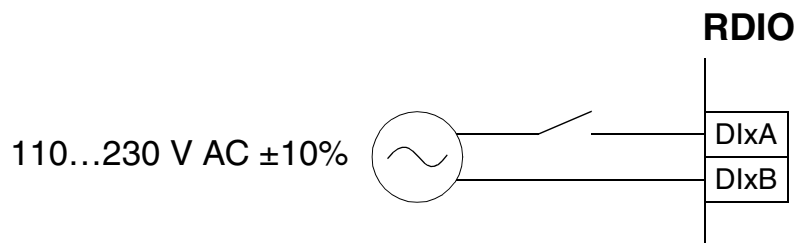

Node ID selection If the RDIO-01 module is mounted onto external I/O Module Adapter AIMA-01, choose the proper node ID for the module using the node ID selector (S1, range 1...15). Setting the node ID is not required when the module is mounted into SLOT 1 or SLOT 2 on the drive.

The default setting of selector S1 is 2.

Programming The communication between the module and the drive is activated by a drive parameter. The RDIO-01 can replace and/or extend certain standard inputs. See the drive *Firmware Manual*, Parameter Group 98.

Note: The new settings take effect only when the module is powered up.

Chapter 4 – Fault tracing

Diagnostic LEDs

There are four diagnostic LEDs on the RDIO-01 module. Three green LEDs show the state of each digital input. Each LED is lit when the corresponding digital input is activated (logical '1'). A yellow LED shows the status of the module.

The status LED is lit when the drive is configuring the module at power-up.

Option slot installation

In case the LED does not go out after one second:

- The configuration has failed.
 - Cycle the power supply of the drive.
- The module has a hardware failure.
 - Ensure the 38-pin connector is properly inserted.
 - Contact an ABB service representative.

I/O Module Adapter installation

- There is no communication with the drive.
 - Check that the drive is powered.
 - Check the module node ID.
 - Check that the fibre optic cables are connected correctly (transmitters to receivers) and the connectors properly inserted.
 - Check the fibre optic cables visually for dirt or flaws.
 - Ensure the 38-pin connector is properly inserted.
 - Try new fibre optic cables.
 - Contact an ABB service representative.

Chapter 4 – Fault tracing

Appendix A – Technical data

Dimensions:

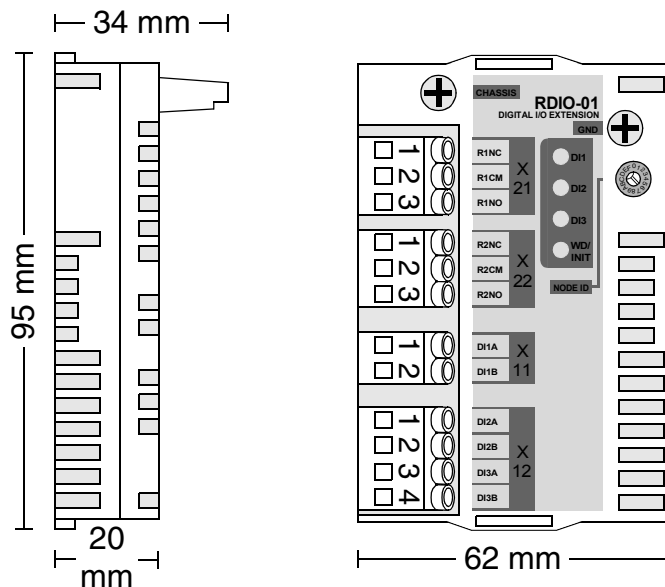

Mounting: Into an option slot of the RMIO board of the drive or onto external I/O Module Adapter (AIMA-01).

Degree of protection: IP 20

Ambient conditions: The applicable ambient conditions specified for the drive in its *Hardware Manual* are in effect.

Hardware settings:

- Rotary switch for node ID selection (range: 1...15)
- One DIP switch for each digital input for disabling/enabling hardware filtering

Connectors:

- 38-pin parallel bus connector
- Four (one 4-pole, one 2-pole, two 3-pole) non-detachable screw-type terminal blocks for max. 2.5 mm² wire.

Digital inputs:

- Input voltages: 24...250 V DC, 110...230 V AC
- Logic levels (DC): "0" < 8 V, "1" > 12 V
- Input currents: 4 mA (min), 10 mA (typical) at 24 V DC, 4 mA (typical) at 230 V AC
- Filtering time (selectable for all channels):
ON: 5...10 ms , OFF: 2 ms
- Updating interval in the ACS 800 Standard Application Program: 12 ms (min.)
- Isolated from each other, the relay outputs, power supply and earth. Test voltages: 2.5 kV rms, 1 minute (DI1 and DI2+DI3); 1.5 kV rms, 1 minute (DI2 and DI3)

Relay outputs:

- Max. contact voltage: 120 V DC, 250 V AC
- Max. contact current / power: 5 A, 24 V DC; 0.4 A, 120 V DC; 1250 VA, 250 V AC
- Max. continuous current: 2 A rms
- Minimum current: 5 mA, 24 V DC
- Contact material: Silver cadmium oxide (AgCdO)
- Contact protection: Varistor (250 V)
- Isolated from each other, the digital inputs, power supply and earth. Test voltage: 2.5 kV rms, 1 minute

General

- Max. power consumption:
150 mA (5 V) + 30 mA (24 V)
Both voltages supplied by the RMIO board
- Estimated min. lifetime: 100 000 h
- All materials UL/CSA-approved
- Complies with EMC standards EN 50081-2 and EN 50082-2



ABB Oy
AC Drives
P.O. Box 184
FIN-00381 Helsinki
FINLAND
Telephone: +358 10 22 11
Fax: +358 10 222 2681
Internet: www.abb.com

ABB Inc.
Drives & Power Products
16250 West Glendale Drive
New Berlin, WI 53151
USA
Telephone: 262 785-8378
800 243-4384
Fax: 262 780-5135

RDIO-01
3AFE 64485733 REV B EN
EFFECTIVE: 10.2.2003