

2600T Series Pressure Transmitters

266 Models

HART

2600T Series Pressure Transmitters
Engineered solutions for all
applications



Company: Joyoung International Trading Co., Limited
Atten: Smiling
Mobile/WhatsApp/Wechat: +86 18050035902
E-mail: info@htechplc.com
Website: <https://www.joyoungintl.com/>

266 Models - HART

Table of contents

Introduction	4	Process connection considerations	23
Instruction manual structure.....	4	Kynar inserts connection.....	23
Models covered by this manual.....	4	Installation recommendations.....	24
Worldwide Service Support Centers.....	4		
Product description	4		
Safety notes	5	Transmitter wiring	28
General safety information	5	Cable connection.....	28
Improper use	6	Analogue output (HART) transmitter wiring.....	29
Technical limit values	6	Supply requirement.....	29
Warranty provision	6	Wiring procedure	30
Plates and symbols.....	6	Electrical connection via connectors	30
Operator liability.....	7	Grounding	31
Qualified personnel	7	Protective grounding.....	31
Returning devices.....	7	Integrated lightning protection.....	31
Disposal	7	Commissioning.....	32
Information on WEEE Directive.....	7	Analogue and HART communication models.....	32
Transport and storage.....	7	Standard setting for normal operation	32
Safety information for electrical installation	7	Standard setting for error detection (alarm).....	32
Safety information for inspection and maintenance.....	8	Write protect.....	33
		Correcting the lower range value / zero shift.....	33
		Set lower range value	33
		Correct the zero shift	33
		Installing / Removing the external pushbuttons.....	34
		Installing / Removing the LCD display	34
		Securing the housing cover in flameproof areas.....	34
Transmitter overview.....	9	Operation	34
Transmitter components overview	9	Local pushbuttons functionality.....	34
Range and Span consideration	10	Factory settings	35
		Configuration types.....	35
Opening the box	10	Configuring the transmitter without an integral LCD HMI.....	35
Packaging content.....	10	LRV an URV configuration.....	35
Identification	10	Correction of zero shift (zero bias / offset).....	36
Optional wired-on SST plate (I1).....	11	Configuration of the pressure transmitter using LCD HMI	36
Handling.....	11	LCD (L1) activation considerations	37
Storage	11	LCD (L5) activation considerations	37
		Activation procedure for TTG (L5) and LCD (L1)	37
Mounting	12	HMI menu structure	37
General	12	Easy Set-up	39
IP protection and designation.....	12	Device Set-up.....	40
Mounting the transmitter	12	Display	44
Transmitter factory configuration consideration	12	Process Alarm	47
Hazardous area consideration	13	Calibrate.....	48
Pressure Equipment Directive (PED) (97/23/CE)	13	Totalizer.....	49
Devices with PS > 200 bar.....	13	Diagnostics	52
Devices with PS < 200 bar.....	13	Device Info	53
Mounting a differential pressure sensor transmitter.....	13	Communication	54
Bracket mounting	14	Damping.....	55
B2 Pipe and wall mounting bracket details.....	18	Transfer function.....	55
B5 Flat type bracket details.....	19	Transfer functions description	55
Mounting a P Style pressure transmitter.....	19	Linear.....	55
B1 and B2 Barrel housing bracket details	20	Square root	55
B2 DIN housing bracket details.....	21	Square root to the 3rd power.....	56
Transmitter housing rotation.....	22	Square root to the 5th power.....	56
Integral display rotation.....	22		
Impulse piping connection for standard instruments.....	22		

Custom linearization curve.....	57
Bidirectional Flow	57
Cylindric lying tank.....	57
Spherical tank	57
Configuration with the PC / laptop or HHT	57
Configuration with graphical user interface	59
Error messages	59
LCD display	59
Error states and alarms.....	60
Error list.....	60
Maintenance	63
Returns and removal.....	63
Pressure transmitter sensor	63
Removing / Installing the process flanges.....	64
Pressure transducer replacement.....	65
Hazardous Area consideration	66
Ex Safety aspects and IP Protection (Europe).....	66
Entities for L5 optional integral LCD display.....	70
Ex Safety aspects and IP Protection (North America).....	70
Additional instruction for IEC 61508 certified device	71
Safety philosophy	71
Application	71
Physical environment	71
Role and responsibilities	71
Management of functional safety.....	71
Information requirements	71
Overall safety life-cycle information.....	71
Applicable laws and standards.....	71
System safety requirement assignment	72
System structure	72
Safety requirement allocation	72
Safety routines.....	72
Commissioning.....	72
Overall system functionality.....	72
Faults outside the functional safety	72
Other consideration	72
Architecture description and principle of operation	73
Principle of operation	73
Commissioning and configuration issues.....	73
Operating mode enabling and disabling	73
Proof tests.....	73
Safety-related parameters.....	74
Trouble sheet	75
Control of substances hazardous to health (C.O.S.H.H.) .	76
EC Declaration of conformity	77

266 Models - HART

Introduction

Instruction manual structure

The present manual provides information on installing, operating, troubleshooting the 266 pressure transmitter. Every section of the present manual is specifically dedicated to the specific phase of the transmitter lifecycle starting from the receipt of the transmitter and its identification, passing to the installation, to the electrical connections, to the configuration and to the troubleshooting and maintenance operations.

Models covered by this manual

The present manual can be used for all the 266 models with exception done for the 266C (multivariable version).

Worldwide Service Support Centers

ABB instrumentation products are supported worldwide by the local ABB Instrumentation branches. In case you fail to get in touch with your country ABB Instrumentation office you may want to get in touch with one of the following center of excellence for ABB Pressure products.

ABB S.p.A.

Via Statale 113,
22016 Lenno (Co) – Italy
Tel: +39 0344 58111
Fax: +39 0344 56278

ABB Inc.

3450 Harvester Road
Burlington, Ontario L7N 3W5 – Canada
Tel: +1 905 6810565
Fax: +1 905 6812810

ABB Automation Product GmbH

Schillerstrasse 72
D-32425 Minden – Germany
Tel: +49 551 905534
Fax: +49 551 905555

ABB Ltd.

32 Industrial Area, NIT,
Faridabad - 121 001, Haryana – India
Tel: +91 129 2448300
Fax: +91 129 2440622

ABB Inc.

125 E. County Line Road
Warminster, PA 18974 – USA
Tel: +1 215 6746000
Fax: +1 215 6747183

ABB (China) Ltd.

35/F Raffles City (Office Tower)
268 Xizang Zhong Zu, 200001 Shanghai – China
Tel: +86 21 6122 8888
Fax: +86 21 6122 8822

Product description

The pressure transmitters model 266 is a modular range of field mounted, microprocessor based electronic transmitters, multiple sensor technologies. Accurate and reliable measurement of differential pressure, gauge and absolute pressure, flow and liquid level is provided, in the even most difficult and hazardous industrial environments. Model 266 can be configured to provide specific industrial output signals according to 4...20mA with HART digital communication.

Safety notes

General safety information

The "Safety" section provides an overview of the safety aspects to be observed for operation of the device.

The device has been constructed in accordance with the state of the art and is operationally safe. It has been tested and left the factory in perfect working conditions. The information in the manual, as well as the applicable documentation and certificates, must be observed and followed in order to maintain this condition throughout the period of operation.

Full compliance with the general safety requirements must be observed during operation of the device. In addition to the general information, the individual sections in the manual contain descriptions of processes or procedural instructions with specific safety information.

Only by observing all of the safety information can you reduce to the minimum the risk of hazards for personnel and/or environment. These instructions are intended as an overview and do not contain detailed information on all available models or every conceivable event that may occur during setup, operation, and maintenance work.

For additional information, or in the event of specific problems not covered in detail by these operating instructions, please contact the manufacturer. In addition, ABB declares that the contents of this manual are not part of any prior or existing agreements, commitments, or legal relationships; nor are they intended to amend these.

All obligations of ABB arise from the conditions of the relevant sales agreement, which also contains the solely binding warranty regulations in full. These contractual warranty provisions are neither extended nor limited by the information provided in this manual.



Caution - Risk

Only qualified and authorized specialist personnel should be charged with installation, electrical connection, commissioning, and maintenance of the transmitter. Qualified personnel are persons who have experience in installation, electrical wiring connection, commissioning, and operation of the transmitter or similar devices, and hold the necessary qualifications such as:

- Training or instruction, i.e., authorization to operate and maintain devices or systems according to safety engineering standards for electrical circuits, high pressures, and aggressive media
- Training or instruction in accordance with safety engineering standards regarding maintenance and use of adequate safety systems

For safety reasons, ABB draws your attention to the fact that only sufficiently insulated tools conforming to DIN EN 60900 may be used.

Since the transmitter may form part of a safety chain, we recommend replacing the device immediately if any defects are detected.

In case of use in Hazardous Area non sparking tools only must be employed.

In addition, you must observe:

- The relevant safety regulations regarding the installation and operation of electrical systems, e.g., German legal regulations governing technical tools, §3 (Gerätesicherheitsgesetz: German Equipment Safety Act)
- The relevant standards, e.g., DIN 31 000/VDE 1000.
- The regulations and guidelines relating to explosion protection, if explosion-proof transmitters have to be installed.



Warning - General Risk

The device can be operated at high levels of pressure and with aggressive media.

As a result, serious injury or significant property damage may occur if this device is operated incorrectly.

266 Models - HART

Improper use

It is prohibited to use the device for the following purposes:

- As a climbing aid, e.g., for mounting purposes
- As a support for external loads, e.g., as a support for pipes, etc.
- Adding material, e.g., by painting over the name plate or welding/soldering on parts
- Removing material, e.g., by drilling the housing.

Repairs, alterations, and enhancements, or the installation of replacement parts, are only permissible as far as these are described in the manual. Approval by ABB must be requested for any activities beyond this scope. Repairs performed by ABB-authorized centers are excluded from this.

Technical limit values

The device is designed for use exclusively within the values stated on the name plates and within the technical limit values specified on the data sheets.

The following technical limit values must be observed:

- The Maximum Working Pressure may not be exceeded.
- The Maximum ambient operating temperature may not be exceeded.
- The Maximum process temperature may not be exceeded.
- The housing protection type must be observed.

Warranty prevision

Using the device in a manner that does not fall within the scope of its intended use, disregarding this manual, using under-qualified personnel, or making unauthorized alterations, releases the manufacturer from any liability for any resulting damage. This makes the manufacturer's warranty null and void.

Plates and symbols



Danger – <Serious damage to health/risk to life>

The appearance of this symbol next to the "Danger" warning indicates that an imminent risk is present. Failure to avoid this will result in death or serious injury.



Warning – <Bodily injury>

The appearance of this symbol next to "Warning" indicates a potentially dangerous situation. Failure to avoid this could result in death or serious injury



Caution – <Minor injuries>

The appearance of this symbol next to "Caution" indicates a potentially dangerous situation. Failure to avoid this could result in minor injuries. This may also be used for property damage warnings.



Attention – <Property damage>

This symbol indicates a potentially damaging situation. Failure to avoid this could result in damage to the product or its surrounding area.



Important

This symbol indicates operator tips or particularly useful information. It does not indicate a dangerous or damaging situation.

Operator liability

Prior to using corrosive and abrasive materials for measurement purposes, the operator must check the level of resistance of all parts coming into contact with the materials to be measured.

ABB will gladly support you in selecting the materials, but cannot accept any liability in doing so.

The operators must strictly observe the applicable national regulations with regard to installation, function tests, repairs, and maintenance of electrical devices.

Qualified personnel

Installation, commissioning, and maintenance of the device may only be performed by trained specialist personnel who have been authorized by the plant operator. The specialist personnel must have read and understood the manual and comply with its instructions.

Returning devices

Use the original packaging or suitably secure shipping package if you need to return the device for repair or recalibration purposes. Fill out the return form (see the end of the document) and include this with the device.

According to EC guidelines and other local laws for hazardous materials, the owner of hazardous waste is responsible for its disposal. The owner must observe the proper regulations for shipping purposes.

All devices sent back to ABB must be free from any hazardous materials (acids, alkalis, solvents, etc.).

Disposal

ABB actively promotes environmental awareness and has an operational management system that meets the requirements of DIN EN ISO 9001:2000, EN ISO 14001:2004, and OHSAS 18001. Our products and solutions are intended to have minimum impact on the environment and persons during manufacturing, storage, transport, use and disposal.

This includes the environmentally friendly use of natural resources. ABB conducts an open dialog with the public through its publications.

This product/solution is manufactured from materials that can be reused by specialist recycling companies.

Information on WEEE Directive 2002/96/EC (Waste Electrical and Electronic Equipment)

This product or solution is not subject to the WEEE Directive 2002/96/EC or corresponding national laws (e.g., the ElektroG - Electrical and Electronic Equipment Act - in Germany).

Dispose of the product/solution directly at a specialist recycling facility; do not use municipal garbage collection points for this purpose. According to the WEEE Directive 2002/96/EC, only products used in private applications may be disposed of at municipal garbage facilities. Proper disposal prevents negative effects on people and the environment, and supports the reuse of valuable raw materials.

ABB can accept and dispose of returns for a fee.

Transport and storage

- After unpacking the pressure transmitter, check the device for transport damage.
- Check the packaging material for accessories.
- During intermediate storage or transport, store the pressure transmitter in the original packaging only.

For information on permissible ambient conditions for storage and transport, see “Technical data”. Although there is no limit on the duration of storage, the warranty conditions stipulated on the order acknowledgment from the supplier still apply.

Safety information for electrical installation

Electrical connections may only be established by authorized specialist personnel in accordance with the electrical circuit diagrams.

The electrical connection information in the manual must be observed; otherwise, the applicable protection type may be affected.

Ground the measurement system according to requirements.

266 Models - HART

Safety information for inspection and maintenance



Warning – Risk to persons

There is no EMC protection or protection against accidental contact when the housing cover is open. There are electric circuits within the housing which are dangerous if touched.

Therefore, the auxiliary power must be switched off before opening the housing cover.



Warning – Risk to persons

The device can be operated at high pressure and with aggressive media.

Any process media released may cause severe injuries.

Depressurize the pipeline/tank before opening the transmitter connection.

Corrective maintenance work may only be performed by trained personnel.

- Before removing the device, depressurize it and any adjacent lines or containers.
- Check whether hazardous materials have been used as materials to be measured before opening the device. Residual amounts of hazardous substances may still be present in the device and could escape when the device is opened.
- Within the scope of operator responsibility, check the following as part of a regular inspection:
 - Pressure-bearing walls/lining of the pressure device
 - Measurement-related function
 - Leak-tightness
 - Wear (corrosion)

Transmitter overview

Transmitter components overview

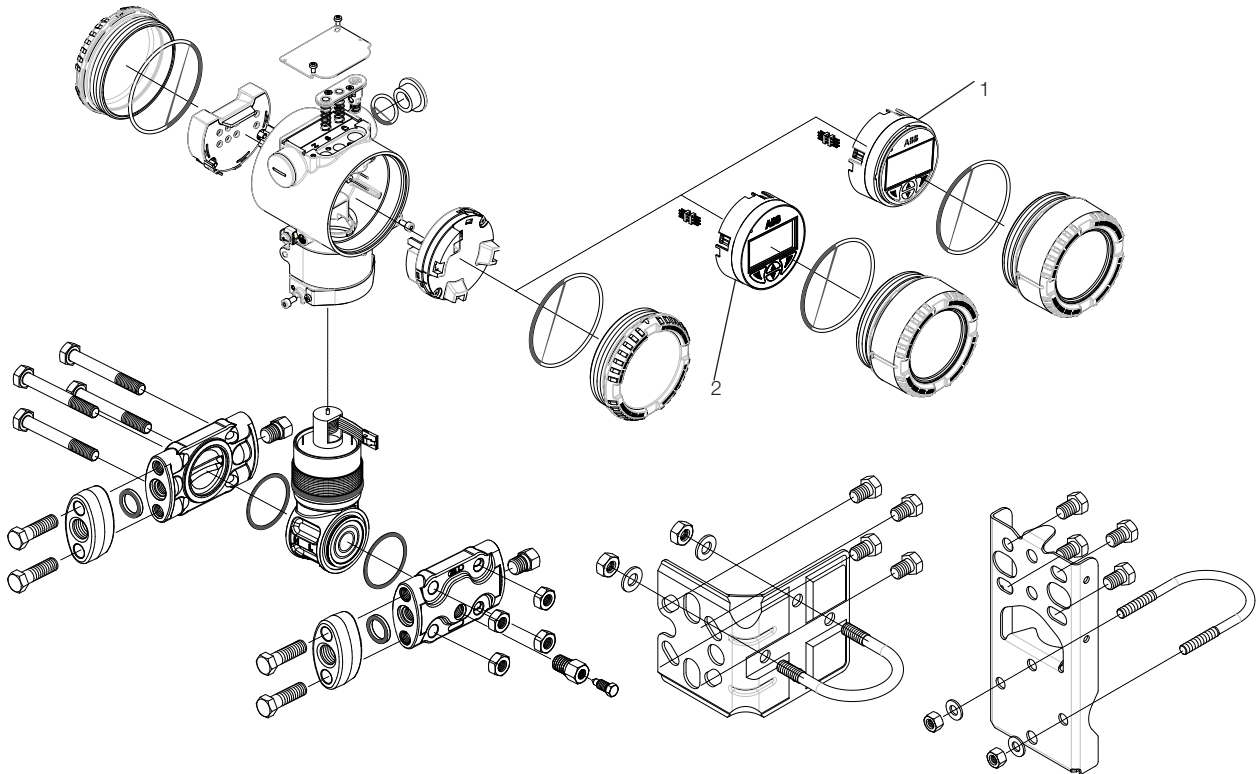

Figure 1: Differential pressure transmitter components

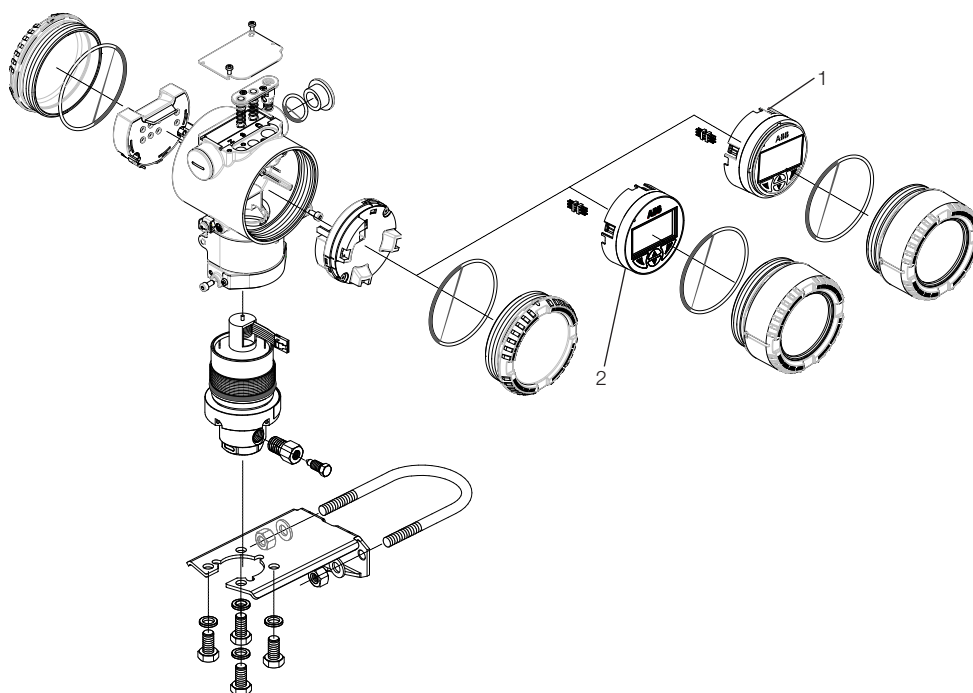

Figure 2: Gauge / absolute pressure transmitter components

- 1 - TTG display (L5 option)
- 2 - LCD display (L1 option)

i Important
 These two pictures show only two different kinds of transmitters equipped with Barrel type housing. Please consider that DIN housings are available.

266 Models - HART

Range & Span consideration

The 2600T Transmitter Specification Sheets provide all information concerning the Range and Span limits in relation to the model and the sensor code.

The terminology currently used to define the various parameters is as follows:

- URL: Upper Range Limit of a specific sensor. The highest value of the measured value that the transmitter can be adjusted to measure.
- LRL: Lower Range Limit of a specific sensor. The lowest value of the measured value that the transmitter can be adjusted to measure.
- URV: Upper Range Value. The highest value of the measured value to which the transmitter is calibrated.
- LRV: Lower Range Value. The lowest value of the measured value to which the transmitter is calibrated.
- SPAN: The algebraic difference between the Upper and Lower Range Values. The minimum span is the minimum value that can be used without degradation of the specified performance.
- TD: (or Turn Down Ratio) is the ratio between the maximum span and the calibrated span.

The transmitter can be calibrated with any range between the LRL and the URL with the following limitations:

$$\text{LRL} \leq \text{LRV} \leq (\text{URL} - \text{CAL SPAN})$$

$$\text{CAL SPAN} \geq \text{MIN SPAN}$$

$$\text{URV} \leq \text{URL}$$

Opening the box

Packaging content:

- Model 266 pressure (or differential pressure) transmitter
- An envelope including the multi-language short instruction manual, the calibration report and the eventual optional requested certificates.
- An Allen key for housing rotation unlocking
- Optional content depending on the selected options:
 - Football adapter to ½" NPT-f and gaskets
 - Bracket kit
 - Flushing rings

Identification

The instrument is identified by the data plates shown in Figure 3.

The certification plate (ref. A): contains the certification related parameters for use in Hazardous area.

The Nameplate (ref.B) provides information concerning the model code, maximum working pressure, range and span limits, power supply, output signal, diaphragms material, fill fluid, range limit, serial number, maximum process working pressure (PS) and temperature (TS).

Please refer to the serial number when making enquiries to ABB service department.

The optional additional SST Tag plate (ref. C - code I2) also provides customer tag number and calibrated range. The instrument may be used as a pressure accessory (category III) as defined by the Pressure Equipment Directive 97/23/EC. In this case, near the CE mark, you will find the number of the notified body (0474) that have verified the compliance. 266 pressure transmitters are in compliance with EMC 2004/108/CE*.

The certification plate (ref.A) shown here is issued by ABB S.p.A, 22016 Lenno, Italy, with the numbers:

FM09ATEX0023X (Ex d)

FM09ATEX0024X (Ex ia)

FM09ATEX0025X (Ex nL)

CE-Identification number of the notified bodies to Pressure Equipment Directive: 0474, to ATEX certification: 0722

The certification plate (ref.A) shown here may also be issued for ABB-APR, 32425 Minden, Germany, with the numbers:

FM09ATEX0068X (Ex d)

FM09ATEX0069X (Ex ia)

FM09ATEX0070X (Ex nL)

CE-Identification number of the notified bodies to Pressure Equipment Directive: 0045, to ATEX certification: 0044

* C and F sensors on gauge and absolute pressure transmitters are in compliance with IEC61000-4-6 with B criteria

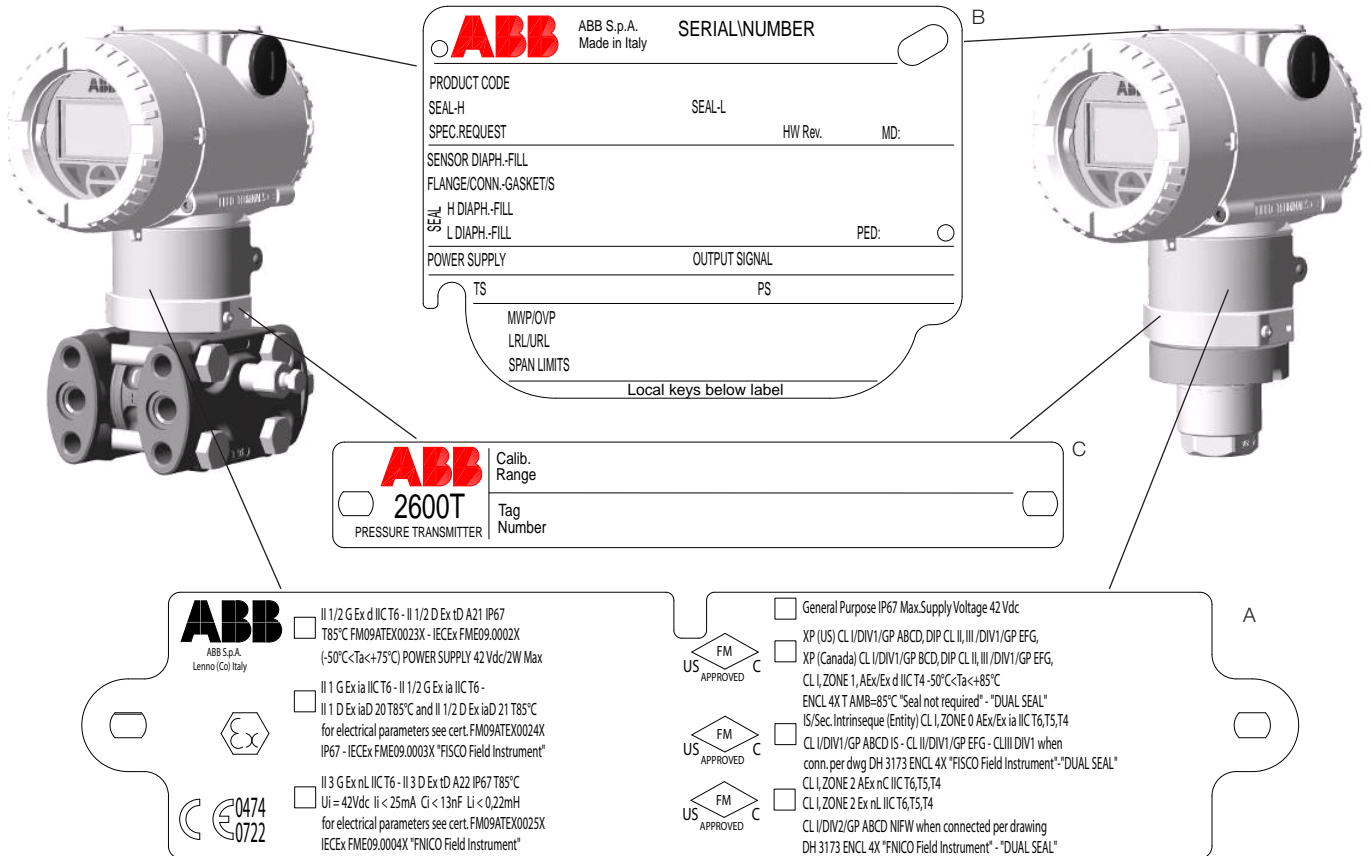

Figure 3: Product identification

Optional wired-on SST plate (I1)

The 266 transmitter can be supplied with the optional “Wired On Stainless Steel plate” (figure 4) which is permanently laser printed with a custom text specified in phase of order. The available space consists in 4 lines with 32 characters per line. The plate will be connected to the transmitter with a Stainless Steel wire.

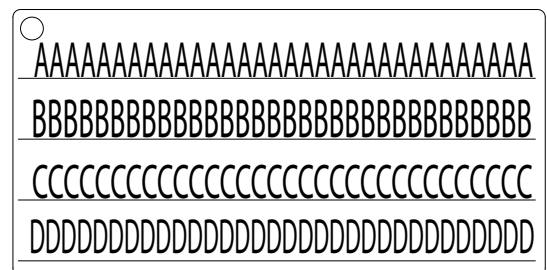

Figure 4: 4-line layout of the optional wired-on Stainless Steel plate

Handling

The instrument does not require any special precautions during handling although normal good practice should be observed.

Storage

The instrument does not require any special treatment if stored as dispatched and within the specified ambient conditions. There is no limit to the storage period, although the terms of guarantee remain as agreed with the Company and as given in the order acknowledgement.

266 Models - HART

Mounting

General

Study these installation instructions carefully before proceeding. Failure to observe the warnings and instructions may cause a malfunction or personal hazard.

Before installing the transmitter, check whether the device design meets the requirements of the measuring point from a measurement technology and safety point of view.

This applies in respect of the:

- Explosion protection certification
- Measuring range
- Gauge pressure stability
- Temperature
- Operating voltage

The suitability of the materials must be checked as regards their resistance to the media. This applies in respect of the:

- Gasket
- Process connection, isolating diaphragm, etc.

In addition, the relevant directives, regulations, standards, and accident prevention regulations must be observed (e.g., VDE/VDI 3512, DIN 19210, VBG, Elex V, etc.).

Measurement accuracy is largely dependent on correct installation of the pressure transmitter and, if applicable, the associated measuring pipe(s). As far as possible, the measuring setup should be free from critical ambient conditions such as large variations in temperature, vibrations, or shocks.



Important

If unfavorable ambient conditions cannot be avoided for reasons relating to building structure, measurement technology, or other issues, the measurement quality may be affected. If a remote seal with capillary tube is installed on the transmitter, the additional operating instructions for remote seals and the related data sheets must be observed.

IP protection & designation

The housings for 266 transmitters are certified as conforming to protection type IP66 / IP67 (according to IEC 60529) or NEMA 4X (according to NEMA 250).

The first number indicates the type of protection the integrated electronics have against the entry of foreign bodies, including dust. "6" means that the housing is dust-proof (i.e., no ingress of dust). The second number indicates the type of protection the integrated electronics have against the entry of water.

"6" means that the housing is protected against water; specifically, powerful jets of water under standardized conditions.

"7" means that the housing is protected against water; specifically, against the effects of temporary immersion in water under standardized water pressure and temporal conditions.

Mounting the transmitter

Transmitter factory configuration consideration

The 266 pressure transmitter in your hands has been factory calibrated to reflect the published declared performance specification; no further calibration is required in normal condition.

ABB typically configures 266 pressure transmitters according to the user requirements. A typical configuration includes:

- TAG number
- Calibrated span
- Output linearization
- LCD display configuration

Hazardous area considerations

The transmitter must be installed in hazardous area only if it is properly certified. The certification plate is permanently fixed on the neck of the transmitter top housing.

The 266 Pressure Transmitter Line can have the following certifications:

ATEX INTRINSIC SAFETY

II 1 G Ex ia IIC T4/T5/T6 and II 1/2 G Ex ia IIC T4/T5/T6

II 1 D Ex iaD 20 T85°C and II 1/2 D Ex iaD 21 T85°C

ATEX EXPLOSION PROOF

II 1/2 G Ex d IIC T6 and II 1/2 D Ex tD A21 IP67 T85°C

ATEX TYPE "N" / EUROPE:

II 3 G Ex nL IIC T4/T5/T6 and II 3 D Ex tD A22 IP67 T85°C

COMBINED ATEX, ATEX FM and FM Canada

See detailed classifications

FM Approvals US and FM Approvals Canada:

Explosionproof (US): Class I, Div. 1, Groups A, B, C, D

Explosionproof (Canada): Class I, Div. 1, Groups B, C, D

Dust ignitionproof : Class II, Div. 1, Groups E, F, G

Nonincendive: Class I, Div. 2, Groups A, B, C, D

Intrinsically safe: Class I, II, III, Div. 1, Groups A, B, C, D, E, F, G

Class I, Zone 0, AEx ia IIC T6/T4 (FM US)

Class I, Zone 0, Ex ia IIC T6/T4 (FM Canada)

IEC (Ex):

See ATEX detailed classifications

INTRINSIC SAFETY/CHINA

NEPSI approval Ex ia IIC T4-T6

FLAMEPROOF/CHINA

NEPSI approval Ex d IIC T6

GOST (Russia), GOST (Kazakistan), Inmetro (Brazil)

based on ATEX.

Pressure Equipment Directive (PED) (97/23/CE)

Devices with PS >200 bar

Devices with a permissible pressure PS >200 bar have been subject to a conformity validation. The data label includes the following specifications:

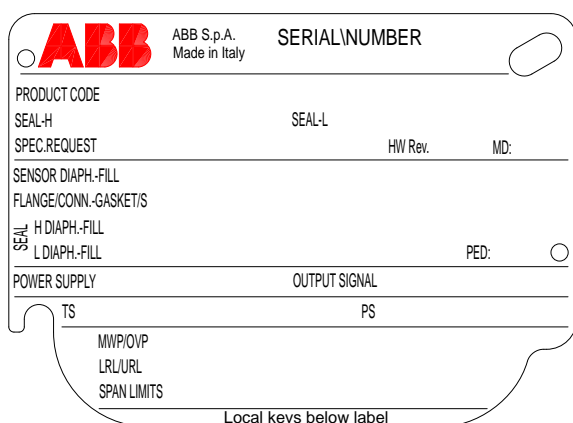

Figure 5: 266 nameplate with PED data

Devices with PS <200 bar

Devices with a permissible pressure PS <200 bar correspond to article 3 paragraph (3). They have not been subject to a conformity validation. These instruments were designed and manufactured acc. to SEP Sound Engineering Practices.

Mounting a Differential Pressure sensor transmitter (266DS/ 266MS /266PS / 266DR / 266PR / 266MR)

The pressure transmitter models 266DS, 266MS and 266PS can be mounted directly on the manifold. A mounting bracket for wall or pipe mounting (2" pipe) is also available as an accessory. For models 266DR, 266PR and 266MR always mounting brackets should be used. Ideally, the pressure transmitter should be mounted in a vertical position to prevent subsequent zero shifts.

i

Important

If the transmitter is installed inclined with respect to the vertical, the filling liquid exerts hydrostatic pressure on the measuring diaphragm, resulting in a zero shift. In such an event, the zero point can be corrected via the zero push-button or via the "set PV to zero" command. Please refer to the [configuration section] for further details. For transmitters without diaphragm seals, please read the following considerations on the Vent/Drain.

!

Attention - Potential damage to transmitter

In case of a High Static differential pressure transmitter (266DSH.x.H) please always open the equalization valve of the manifold (if installed) before applying pressure to the transmitter. High Static pressure can damage the sensor causing a zero shift and a serious decrease of the total performance in terms of accuracy. In this case, please perform a full sensor trim.

266 Models - HART

It is important to mount the transmitter and to lay the process piping so that gas bubbles, when measuring liquids, or condensate when measuring gases, will flow back to the process and not enter the transmitter measuring chamber. Optional Vent/drain valves (code V1/V2/V3) on the transmitter are located on the sensor flanges.

The transmitter has to be positioned so that these drain/vent valves will be located higher than the taps on liquid service in order to allow the venting of entrapped gas or below the taps on gas service in order to allow the air to vent off or condensate to drain off.

For safety reasons, take care of the drain/vent valves position so that when the process fluid is removed during the drain/vent operation it is directed down and away from technicians. It is recommended to mount the transmitter to prevent this possible source of damage for unskilled operators.

Bracket mounting (optional)

Different mounting brackets are available please refer to the relevant installation drawing below



Figure 6: Drain/vent valves configuration (respectively V1, V2, V3)



Important

In case of a High Static differential pressure transmitter, please notice that the Vent/Drain valves can be configured only on the process axis (V1).

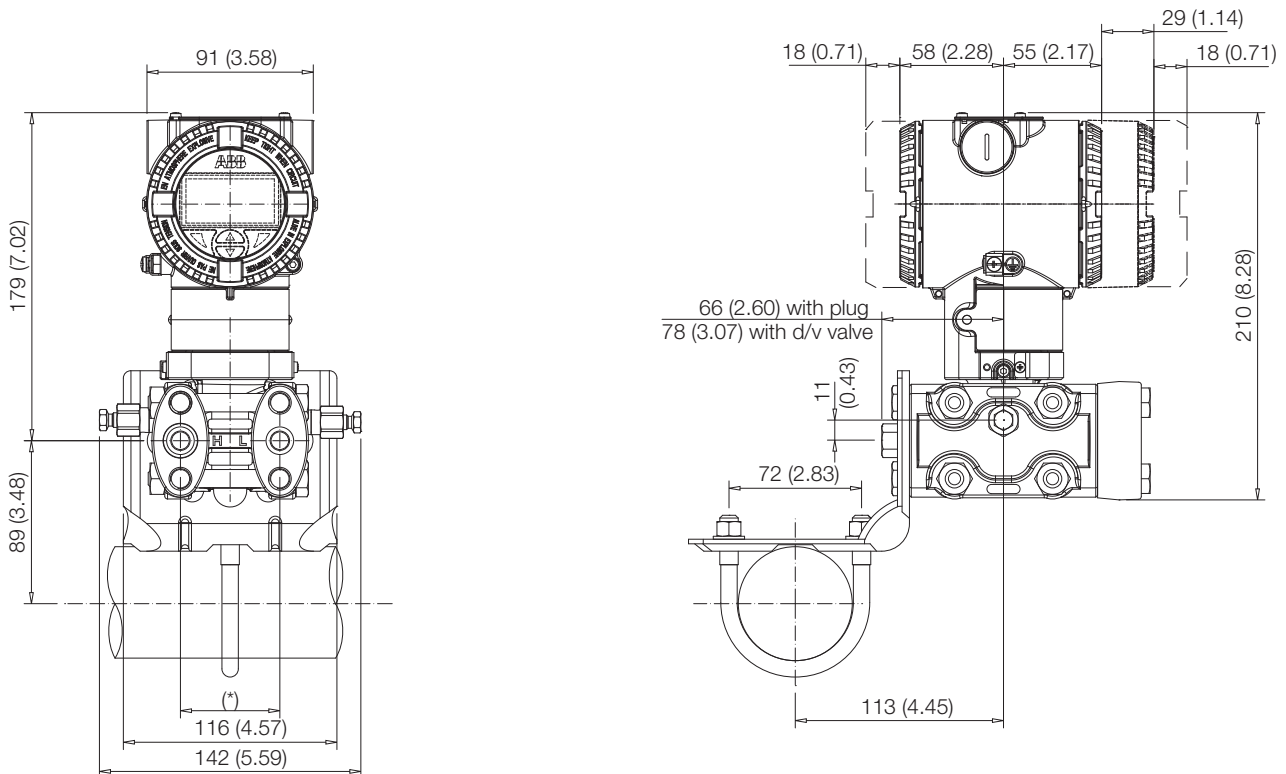

Figure 7a: Differential Pressure Style transmitter with barrel housing installed on a horizontal pipe with optional bracket (B2)

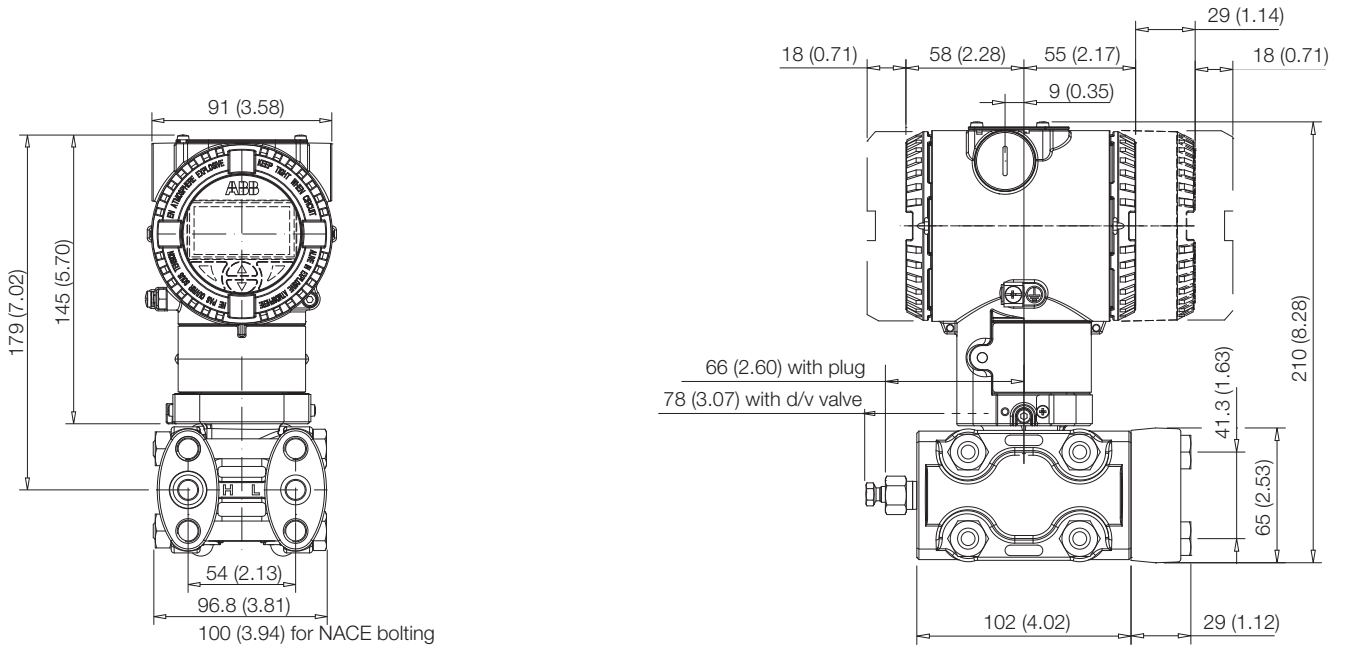

Figure 7b: Differential Pressure Style transmitter (High Static option)

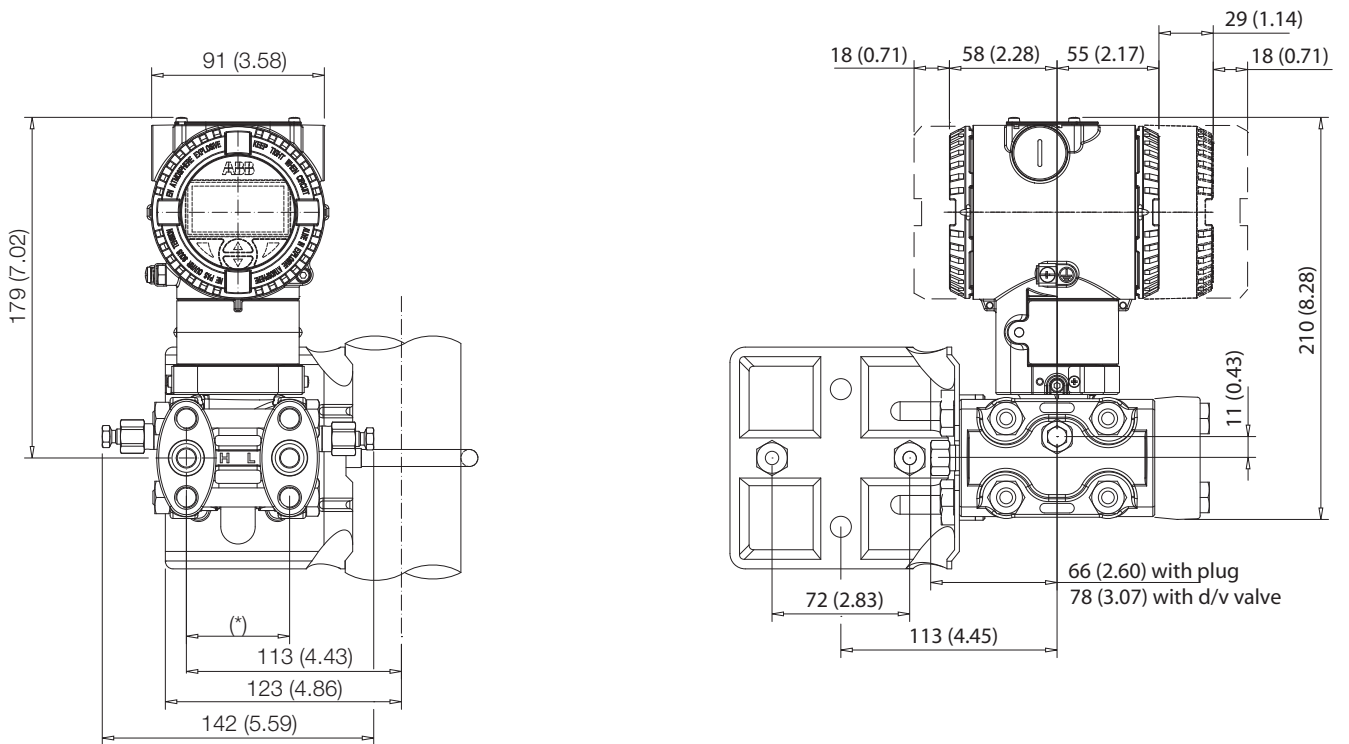

Figure 8: Differential Pressure Style transmitter with barrel housing installed on a vertical pipe with optional bracket (B2)

266 Models - HART

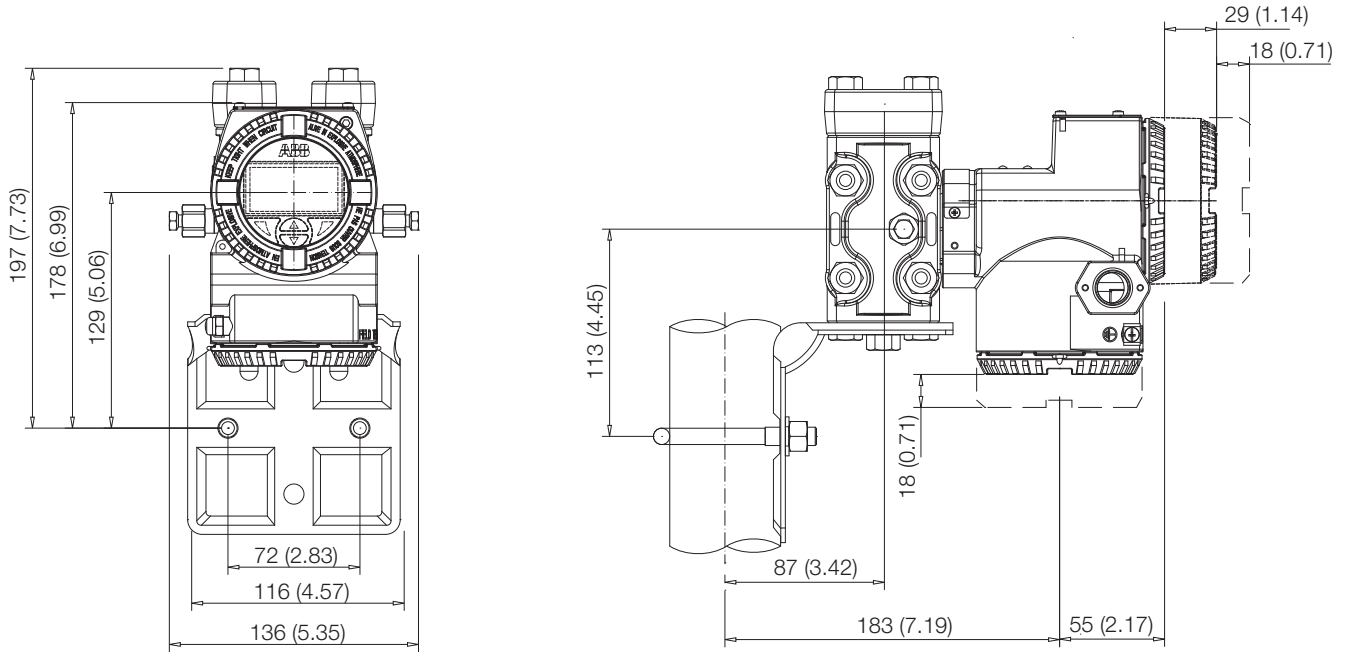

Figure 9: Differential Pressure Style transmitter with DIN housing installed on a Vertical pipe with optional bracket (B2) installation for AIR/GAS measurements

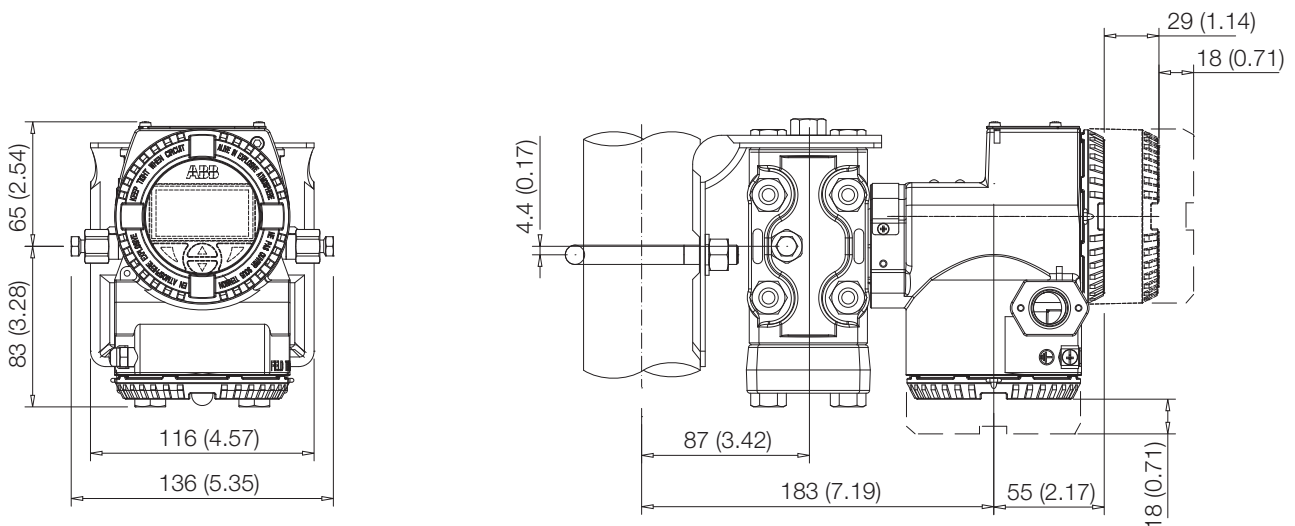

Figure 10: Differential Pressure Style transmitter with DIN housing installed on a Vertical pipe with optional bracket (B2) installation for LIQUID measurements

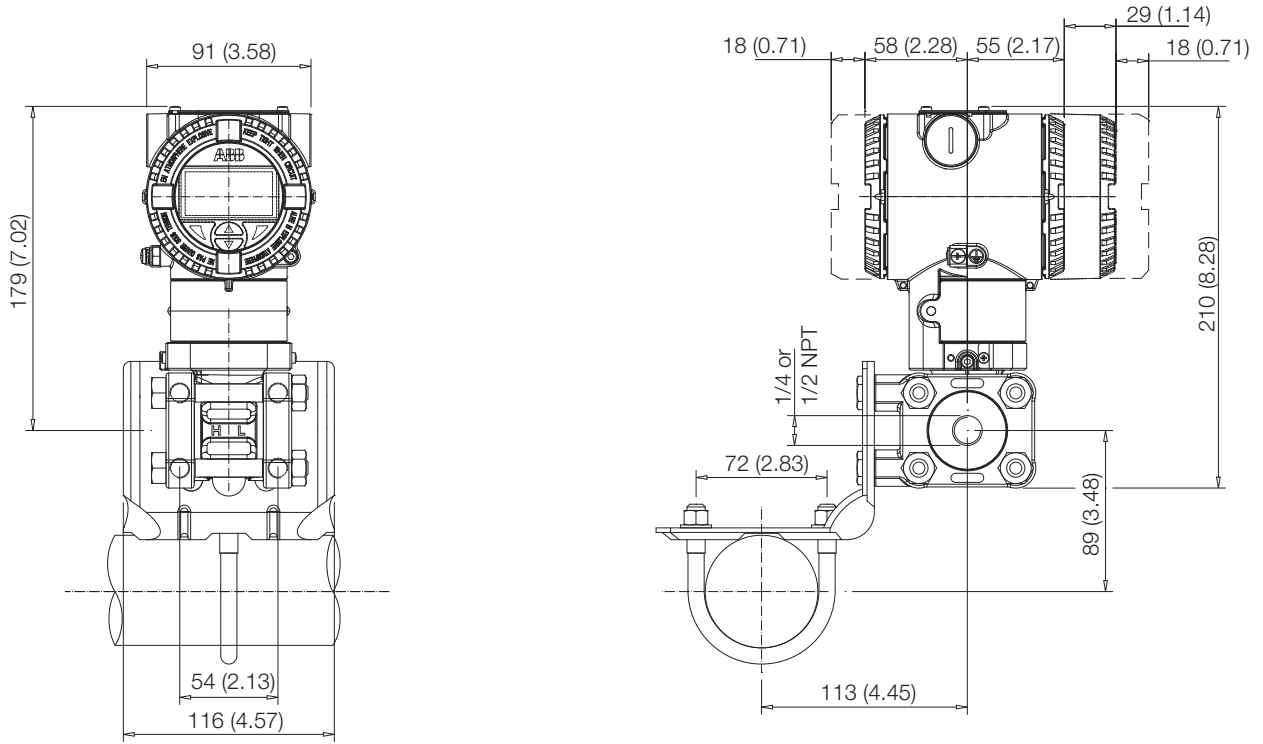

Figure 11: Differential Pressure Style transmitter with barrel housing and Kynar inserts installed on a horizontal pipe with optional bracket (B2)

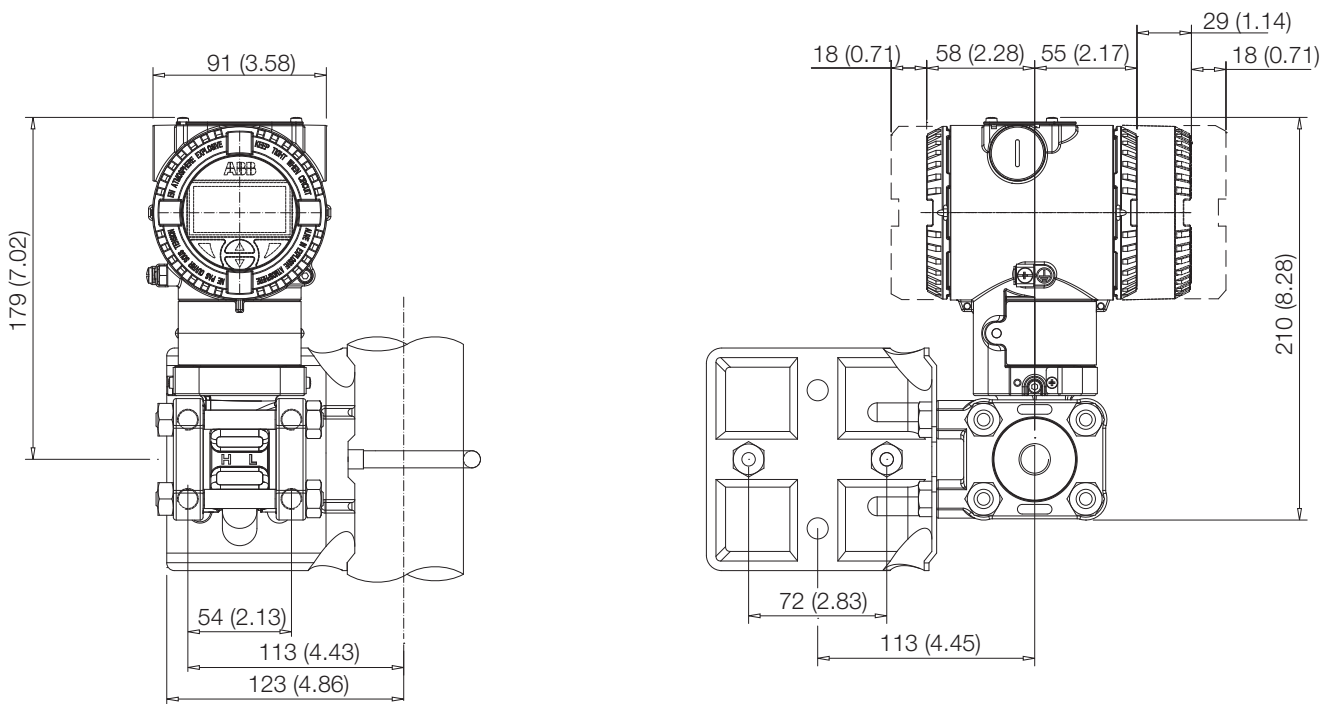

Figure 12: Differential Pressure Style transmitter with barrel housing and Kynar inserts installed on a vertical pipe with optional bracket (B2)

266 Models - HART

B2 Pipe and wall mounting bracket details

All the bolts and nuts supplied are necessary for the installation on pipe. In case a panel or wall installation will be done, the U-bolt and the U-bolt nuts and washers will not have to be used. The bolts for panel mounting are not within the scope of supply.

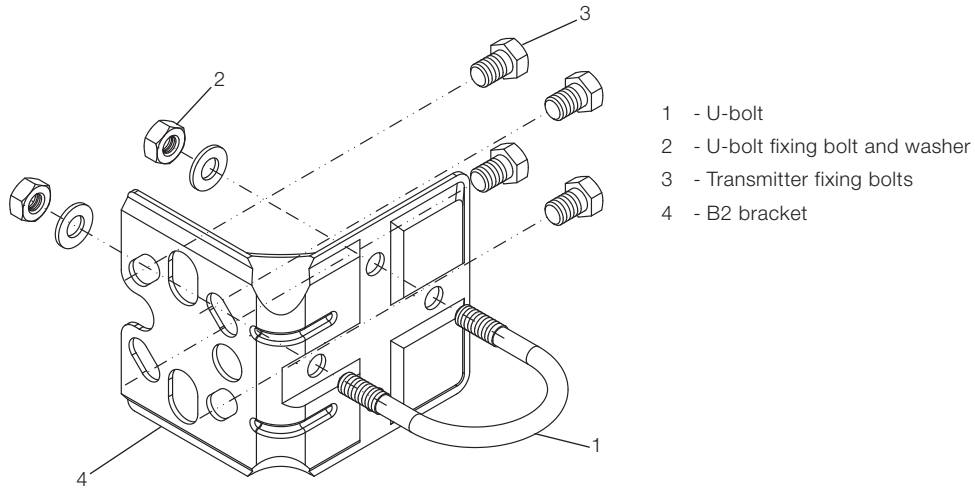

Figure 13: Pipe and wall mounting bracket kit (B2)

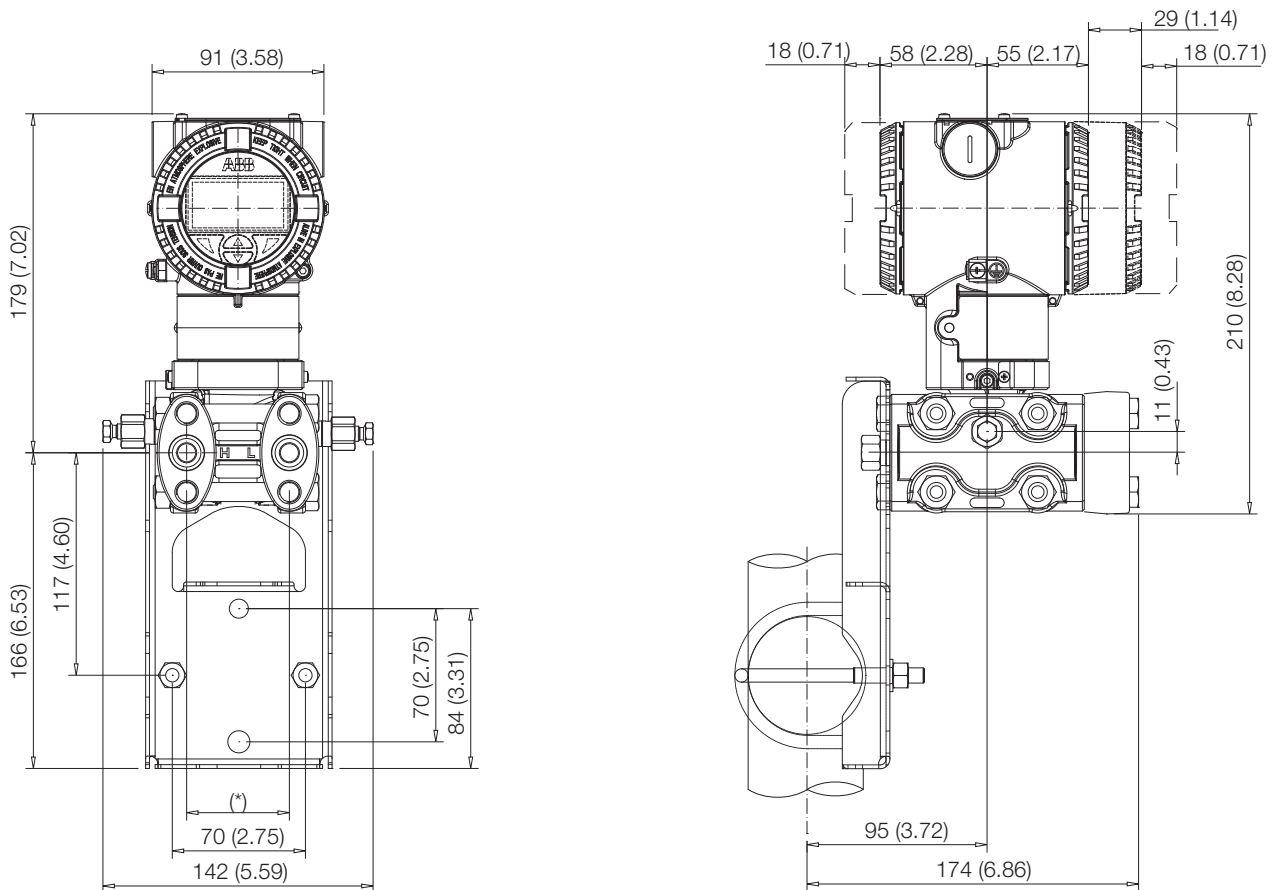

Figure 14: Differential Pressure Style transmitter with barrel housing installed on a box pipe with optional bracket for SST housing (B5)

B5 Flat type bracket details

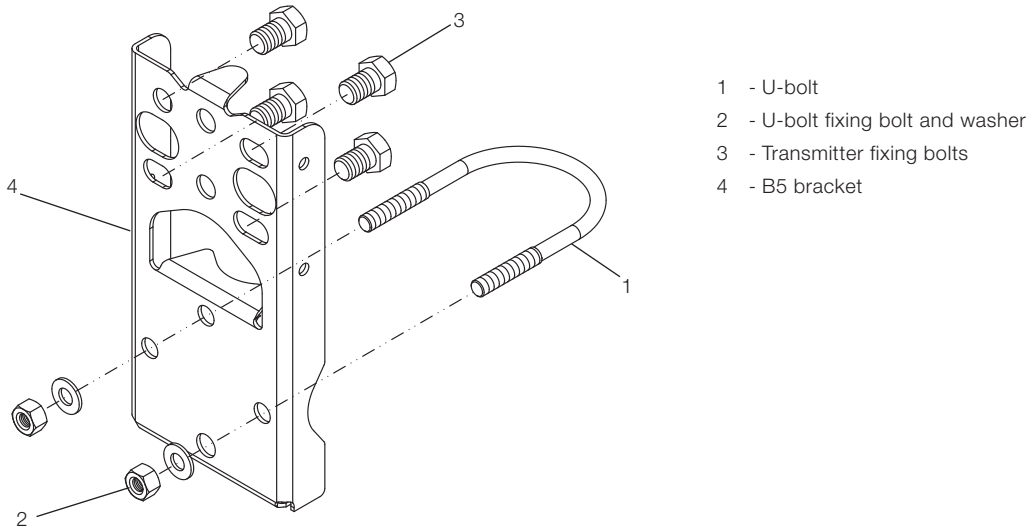

Figure 15: Flat type mounting bracket kit (B5)

Mounting a P style pressure transmitter (266G, 266A, 266H, 266N)

The pressure transmitter can be mounted directly on the manifold.

A mounting bracket for wall or pipe mounting (2" pipe) is also available as an accessory.

Ideally, the pressure transmitter should be mounted in a vertical position to prevent subsequent zero shifts.

i Important
 If the transmitter is installed inclined with respect to the vertical, the filling liquid exerts hydrostatic pressure on the measuring diaphragm, resulting in a zero shift. In such an event, the zero point can be corrected via the zero push-button or via the "set PV to zero" command. Please refer to the [configuration section] for further details. For transmitters without diaphragm seals the Vent / Drain considerations below should be taken into consideration.

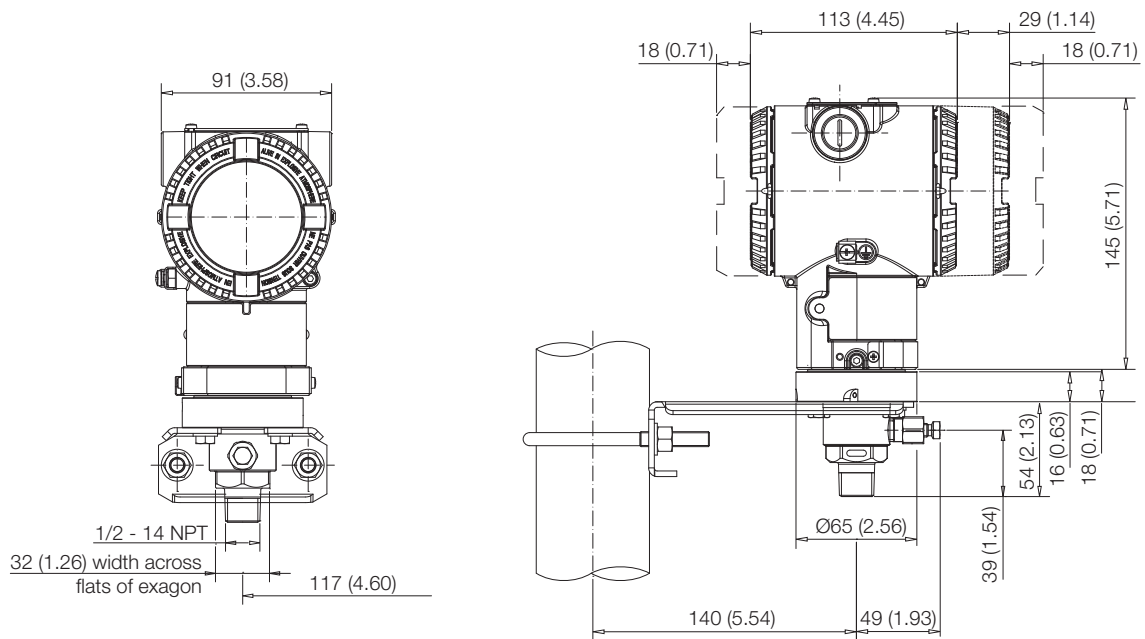

Figure 16: Model 266H or 266N Hi overload resistant P-Style transmitter with barrel housing installed on a 2" pipe with optional bracket (B1 carbon steel or B2 Stainless Steel 316L)

266 Models - HART

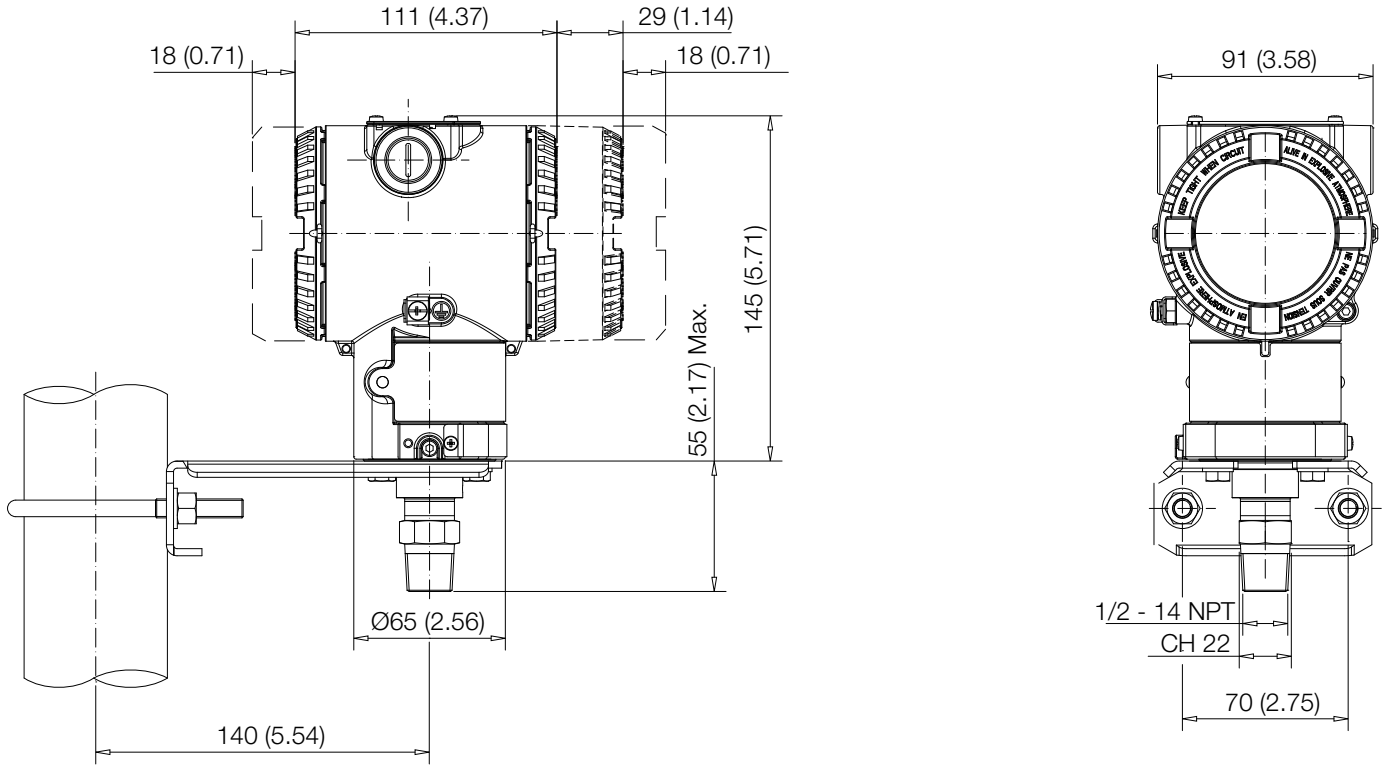

Figure 17: Model 266G or 266A P-Style transmitter with barrel housing installed on a 2" pipe with optional bracket (B1 carbon steel or B2 Stainless Steel 316L)

B1 and B2 Barrel housing bracket details

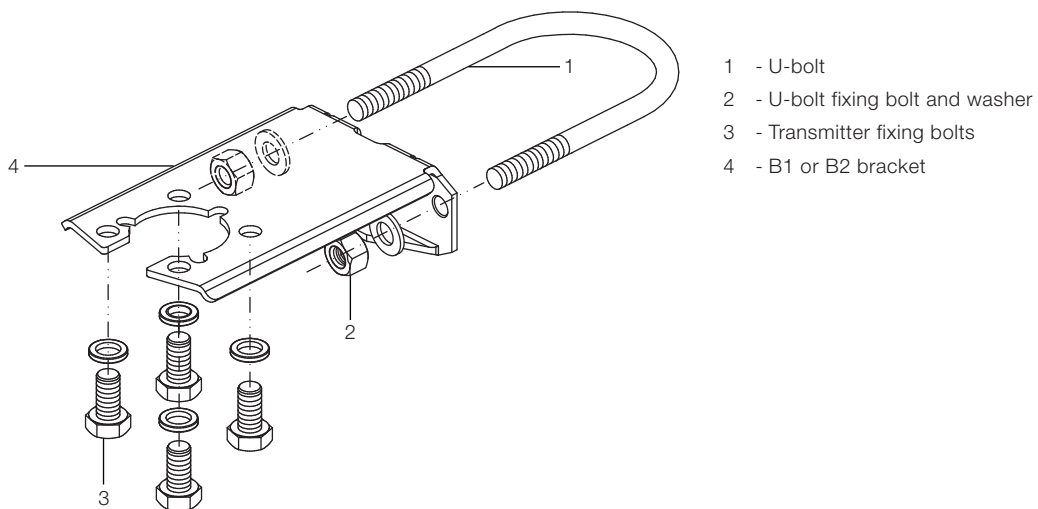

Figure 18: Pipe and wall mounting bracket kit (B1 and B2) for P style transmitter with Barrel housing

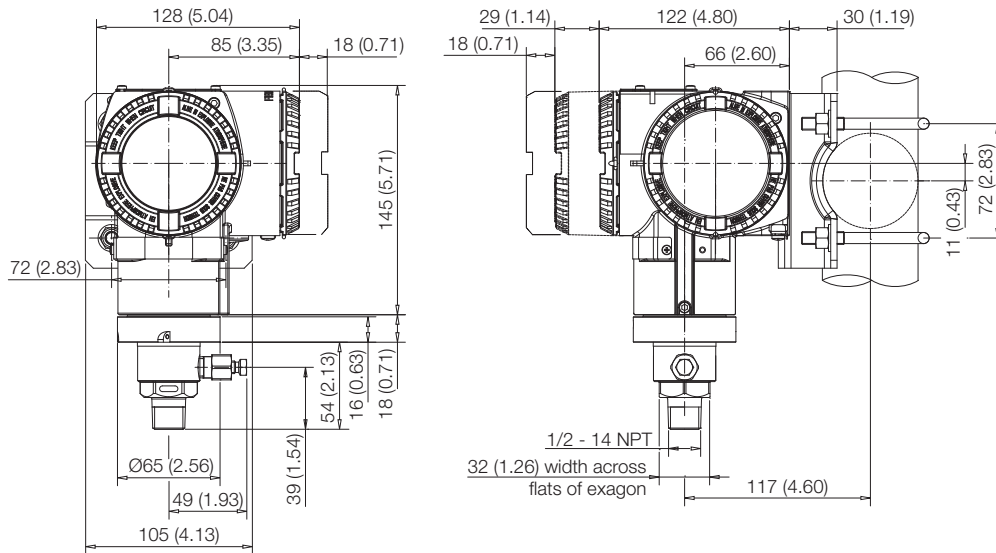

Figure 19: Model 266H or 266N Hi overload resistant P-Style transmitter with DIN housing installed on a 2" pipe with optional bracket (B2 Stainless Steel 316L)

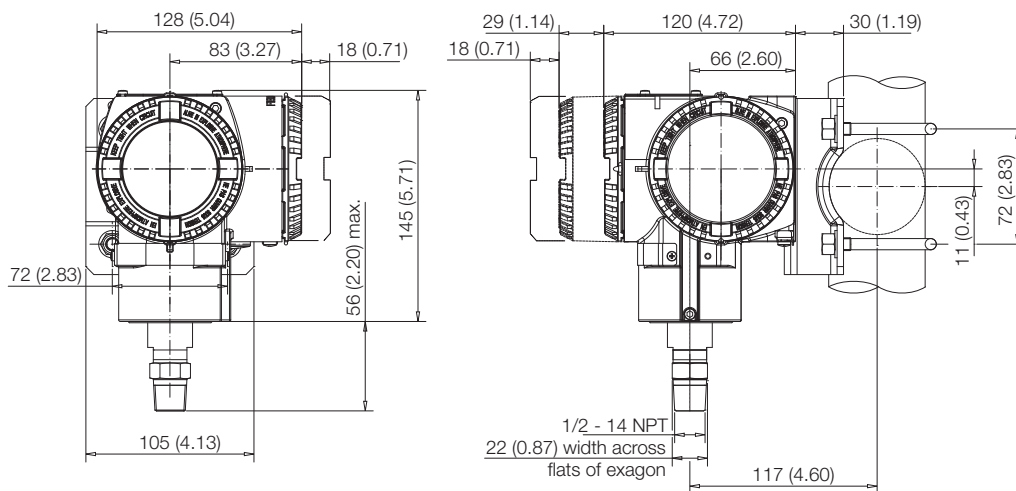

Figure 20: Model 266G or 266A P-Style transmitter with DIN housing installed on a 2" pipe with optional bracket (B2 Stainless Steel 316L)

B2 DIN Housing bracket details

- 1 - U-bolt
- 2 - U-bolt fixing bolt and washer
- 3 - Transmitter fixing bolts
- 4 - B2 bracket

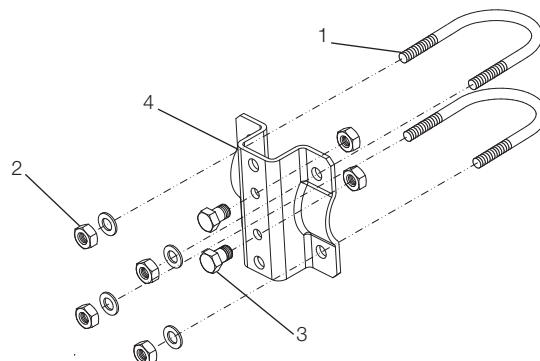

Figure 21: Pipe and wall mounting bracket kit (B2) for P style transmitter with DIN housing

266 Models - HART

Transmitter housing rotation

To improve field access to the wiring or the visibility of the optional LCD meter, the transmitter housing may be rotated through 360° and fixed in any position. A stop prevents the housing from being turned too far.

In order to proceed with housing rotation, the housing stop tang-screw has to be unscrewed by approximately 1 rotation (do not pull it out) and, once the desired position has been reached, retightened.

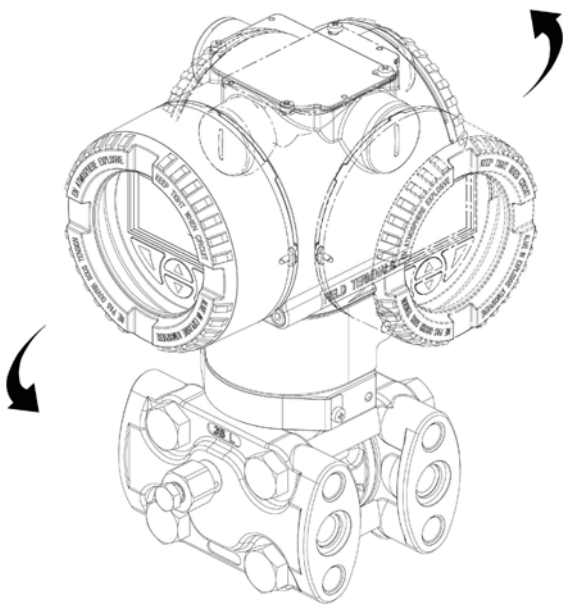

Figure 22: Housing rotation

Integral Display Rotation

In case an optional integral display meter is installed, it is possible to mount the display in four different positions rotated clockwise or counterclockwise with 90° steps.

To rotate the LCD, simply open the windowed cover (Hazardous area prescriptions must be respected), pull-out the display housing from the communication board. Reposition the LCD connector according to the new desired position. Push back the LCD module on the communication board. Be sure that the 4 plastic fixing locks are properly in place.

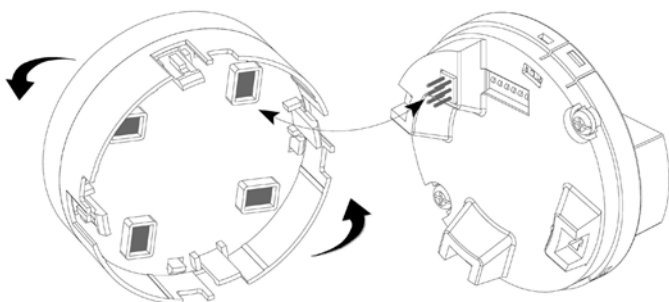

Figure 23: LCD rotation

Impulse piping connection for standard instruments

In order for the pipes to be laid correctly, the following points must be observed:

- The measuring pipes must be as short as possible and free from sharp bends.
- Lay the impulse piping in such a way that no deposits can accumulate in them. Gradients should not be less than approx. 8 % (ascending or descending).
- The measuring pipes should be blown through with compressed air or, better yet, flushed through with the measuring medium before connection.
- Where a fluid/vaporous measuring medium is being used, the liquid in both measuring pipes must be at the same level. If a separating liquid is being used, both measuring pipes must be filled to the same level (266Dx and 266Mx).
- Although it is not absolutely necessary to use balancing vessels with vaporous measuring media, measures must be taken to prevent steam entering the measuring chambers of the measuring equipment (266Dx and 266Mx).
- It may be necessary to use condensate vessels, etc., with small spans and vaporous measuring media (266Dx and 266Mx).
- If using condensate vessels (steam measurement), you should ensure that the vessels are at the same elevation in the differential pressure piping (266Dx and 266Mx).
- As far as possible, keep both impulse lines at the same temperature (266Dx and 266Mx).
- Completely depressurize the impulse lines if the medium is a fluid.
- Lay the impulse lines in such a way that gas bubbles (when measuring fluids) or condensate (when measuring gases) can flow back into the process line.
- Ensure that the impulse lines are connected correctly (High and Low pressure sides connected to measuring equipment, seals, etc.).
- Make sure the connection is tight.
- Lay the impulse line in such a way that prevents the medium from being blown out over the measuring equipment.



Caution

Process leaks may cause harm or result in death.

Install and tighten process connectors and all accessories (including manifolds) before applying pressure. In case of toxic or otherwise dangerous process fluid, take any precautions as recommended in the relevant Material Safety Data Sheet when draining or venting. Use only a 12 mm (15/32 ") hexagonal spanner to tighten the bracket bolts.

Process connections considerations

266 differential pressure transmitter process connections on the transmitter flange are 1/4 - 18 NPT, with a centers distance of 54mm (2.13in) between the connections. The process connections on the transmitter flange are on centers to allow direct mounting to a three-valve or five-valve manifold.

Flange adapter unions with 1/2 - 14 NPT connections are available as an option. Rotate one or both of the flange adapters to attain connection centers of 51mm (2.01in), 54mm (2.13in) or 57mm (2.24in).

To install adapters, perform the following procedure:

- Position the adapters with the O-ring in place.
- Bolt the adapters to the transmitter flange using the bolts supplied.

Tighten the bolts to a torque value of 25Nm (stainless steel bolts) or 15Nm (for Stainless steel NACE bolts).

- Deviations for models 266Mx, 266Rx and for PTFE O-rings: pretightening hand-tight. Pretightening to 10 Nm. Final tightening to 50 Nm.

- For model 266PS, 266VS and 266RS, it is only possible to have one adapter, with low pressure side flange without process connection and drain/vent valve.

- For high static model (266DSH.x.H) tighten the bolts to a torque value of 40 Nm (regardless of the material of the bolts used). In case of PTFE O-rings, pretightening to 10 Nm and final tightening to 50 Nm.

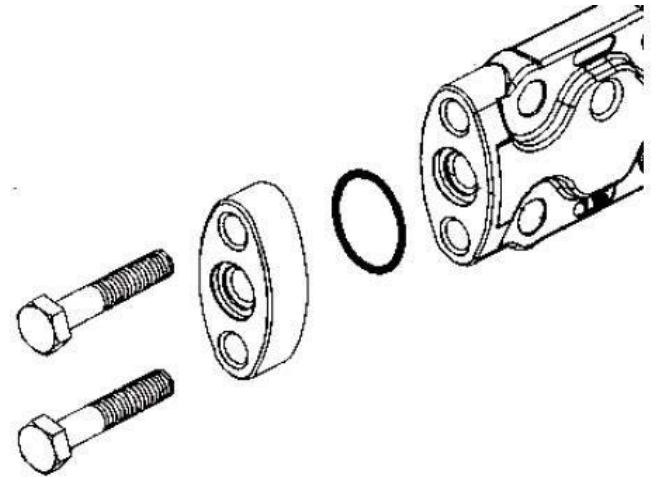

Figure 24: Flange adapter

Kynar inserts connection

When connecting Pressure transmitters equipped with kynar inserts tighten the bolts to 15 Nm max.

Screw torques for models 266MS and 266RS with Kynar inserts

The following procedures apply to process flange screws and nuts:

Pretightening to 2 Nm (working crosswise).

Pretightening to 10 Nm (working crosswise) and then tightening by a tightening angle of 180°, working in two stages of 90° for each screw, and working crosswise.



Figure 25: Kynar insert

266 Models - HART

Installation recommendations

Impulse piping configuration depends on the specific measurement application.

Steam (condensable vapor) or clean liquids flow measurement

- Place taps to the side of the line.
- Mount beside or below the taps.
- Mount the drain/vent valve upward.
- In case of steam application fill the vertical section of the connecting lines with a compatible fluid through the dedicated filling tees.

The process fluid must enter the transmitter primary:

- Open equalizing valve (C)
- Close low pressure (B) and high pressure (A) valves .
- Open gate valves
- Slowly open high pressure (A) valve to admit process fluid to both sides of primary.
- Vent or drain the primary unit and then close the valves.
- Open the (B) valve and close the equalizing valve.

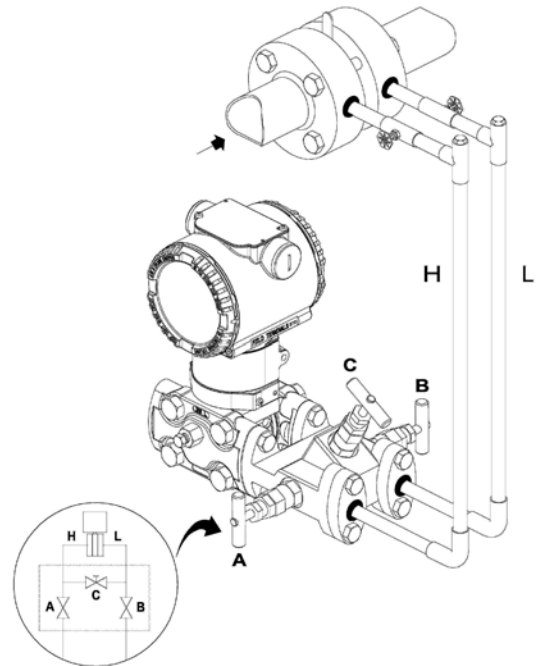

Figure 26: Steam or clean liquid flow measurement (transmitter and manifold)

Gas or liquid (with solids in suspension) Flow Measurement

- Place the taps to the top or side of the line.
- Mount the transmitter above the taps.

The process fluid must enter the transmitter primary:

- Open equalizing valve (C)
- Close low pressure (B) and high pressure (A) valves .
- Open gate valves
- Slowly open high pressure (A) valve to admit process fluid to both sides of primary.
- Vent or drain the primary unit and then close the valves.
- Open the (B) valve and close the equalizing valve.

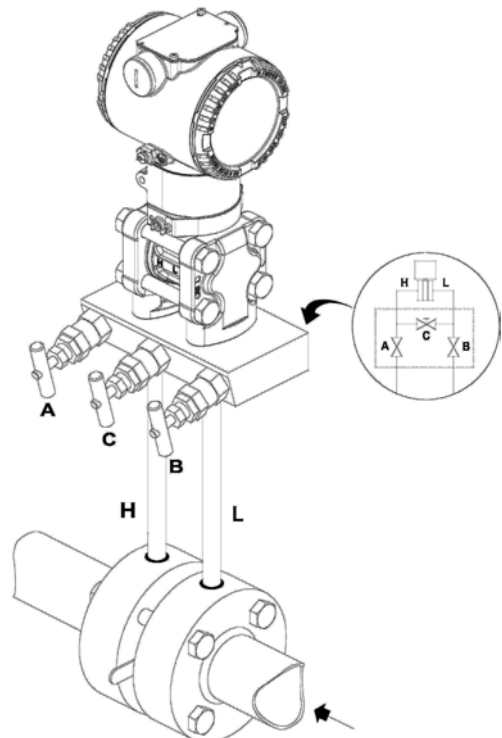

Figure 27: Gas or liquid flow measurement (transmitter and manifold)

Liquid Level Measurements on closed tanks and non condensable fluids (dry leg)

- Mount the transmitter at the same height or below the lowest level to be measured.
- Connect the + (H) side of the transmitter to the bottom of the tank.
- Connect the - (L) side of the transmitter to the upper part of the tank, above the maximum level of the tank.

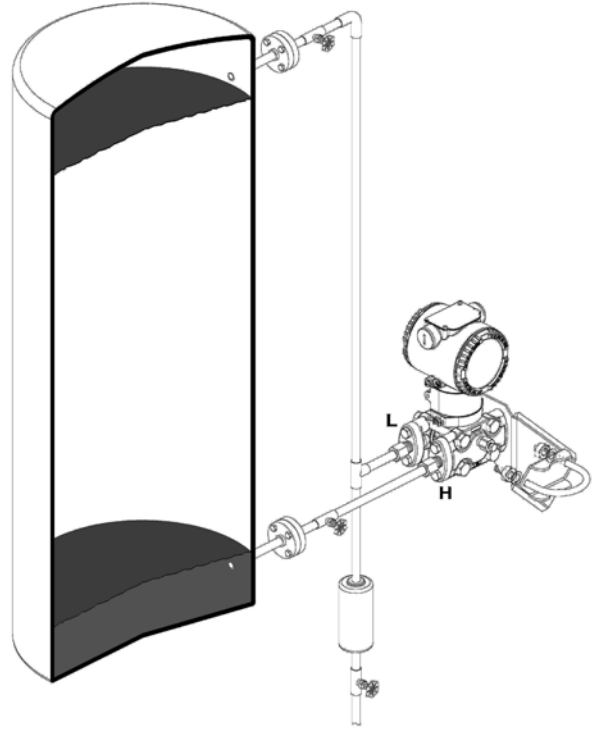

Figure 28: Level measurement on closed tank with dry leg

Liquid Level measurement with closed tanks and condensable fluids (wet leg)

- Mount the transmitter at the same height or below the lowest level to be measured.
- Connect the + (H) side of the transmitter to the bottom of the tank.
- Connect the - (L) side of the transmitter to the upper part of the tank.
- Fill the vertical section of the connecting line to the upper part of the tank with a compatible liquid through the dedicated filling tee.

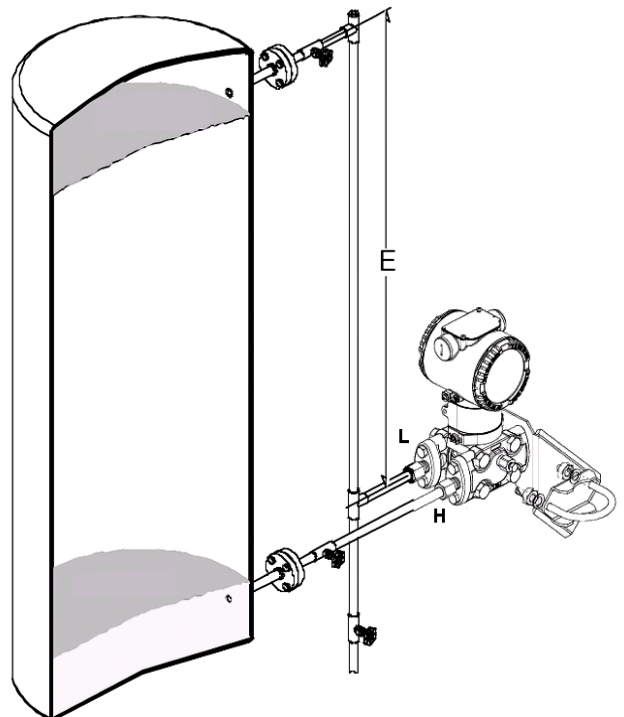

Figure 29: Level measurement on closed tank with wet leg

266 Models - HART

Liquid Level Measurement with open tanks

- Mount the transmitter at the same height or below the lowest level to be measured.
- Connect the + (H) side of the transmitter to the bottom of the tank.
- Vent the “-” (L) side of the transmitter to the atmosphere (in this case a gauge pressure is shown; the (L) side is already vented to the atmosphere).

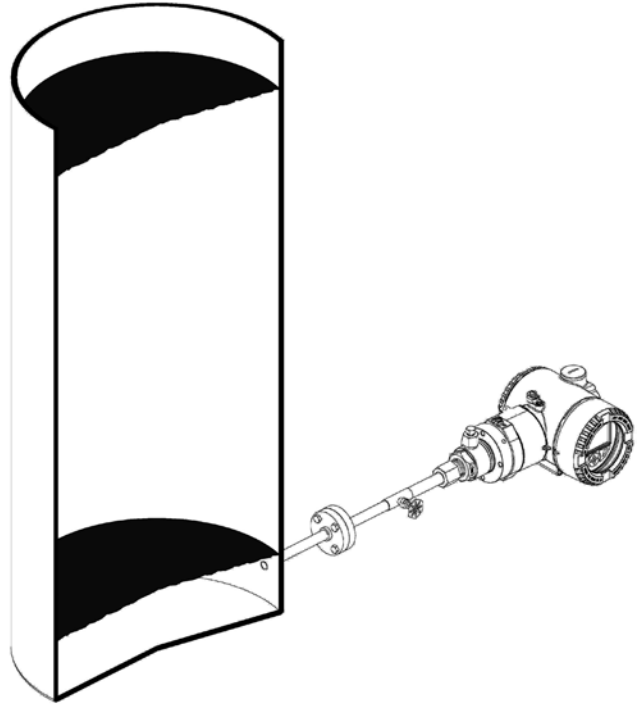

Figure 30: Level measurement on open tank with P style transmitter

Pressure or Absolute Pressure measurement of a tank

- Place the taps in the upper part of the tank.
- Mount the transmitter above the elevation of the process tap.
- Connect the transmitter to the tank.

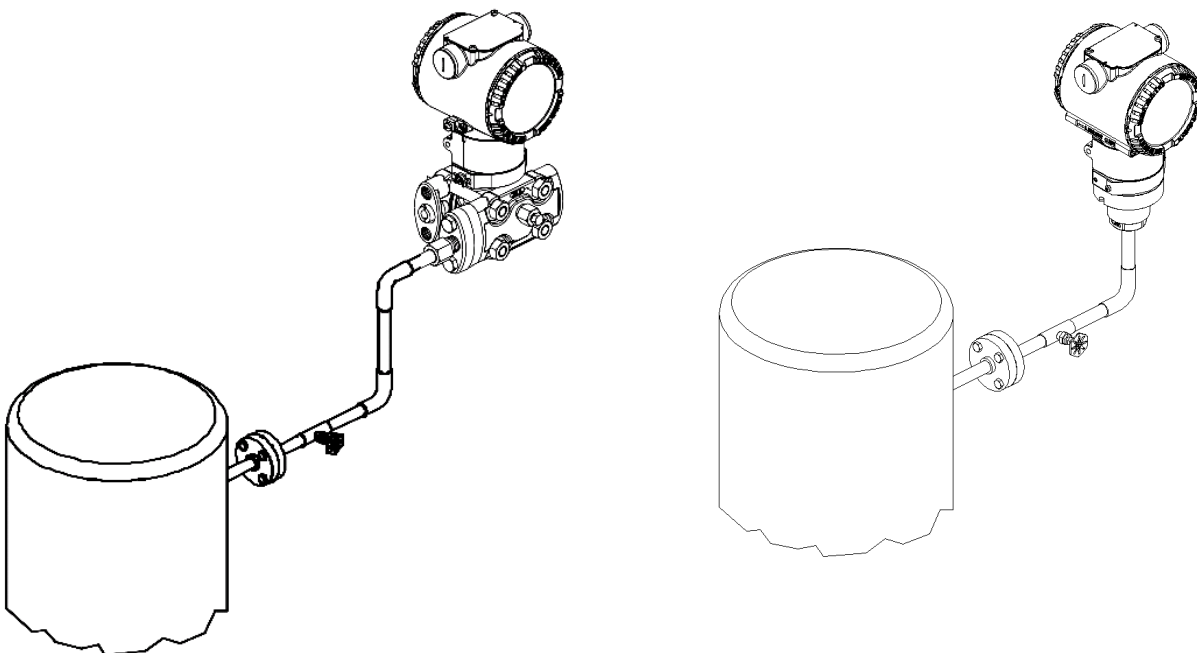

Figure 31: Gauge or absolute pressure measurement on a tank with DP and P style transmitter

Pressure or absolute pressure measurement of a liquid in a pipe

- Place the tap at the side of the line.
- Mount the transmitter beside or below the tap for clean fluids, above the tap for dirty fluids.
- Connect the + (H) side of the transmitter to the pipe.

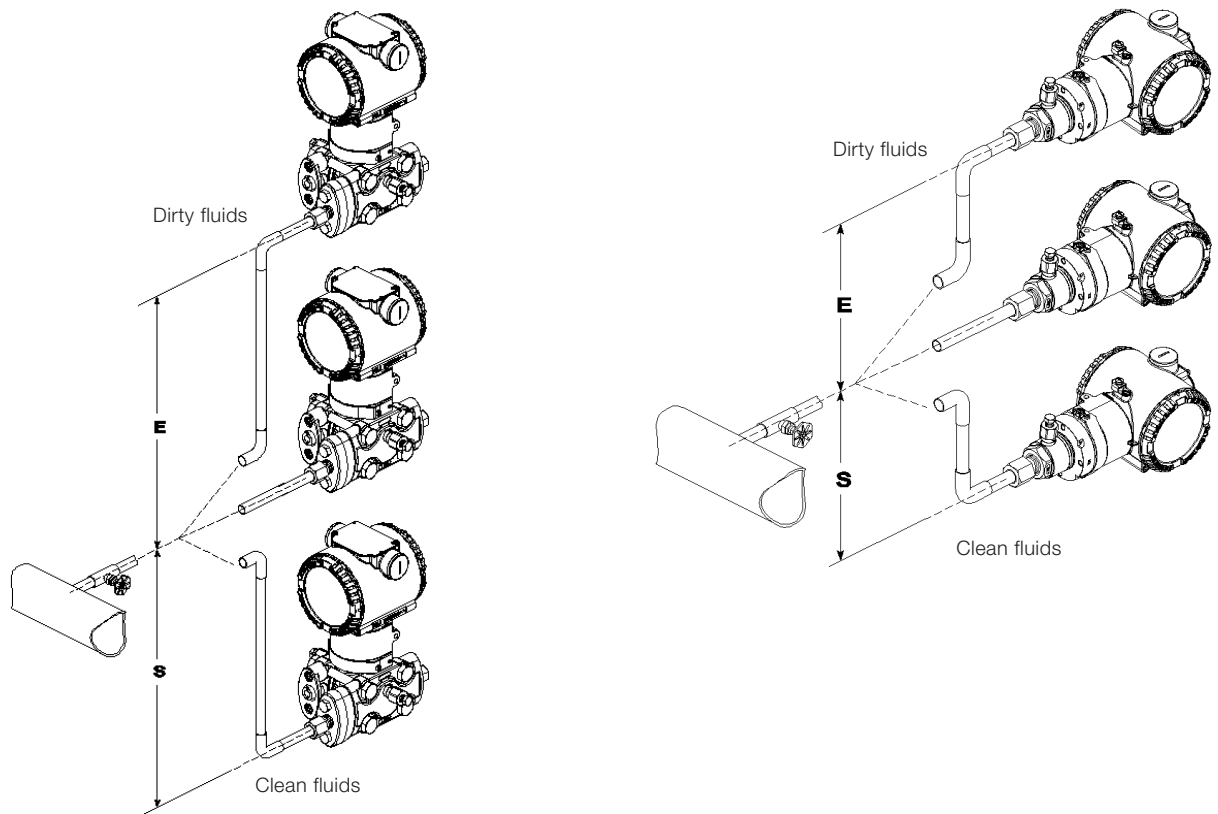

Figure 32: Gauge or absolute pressure measurement of a liquid in a pipe with DP and P style transmitter

Pressure or absolute pressure measurement of a condensable vapor in a pipe

- Place the tap at the side of the line.
- Mount the transmitter below the tap.
- Connect the + (H) side of the transmitter to the pipe.
- Fill the vertical section of the connecting line to the tap with a compatible liquid through the dedicated filling tee.

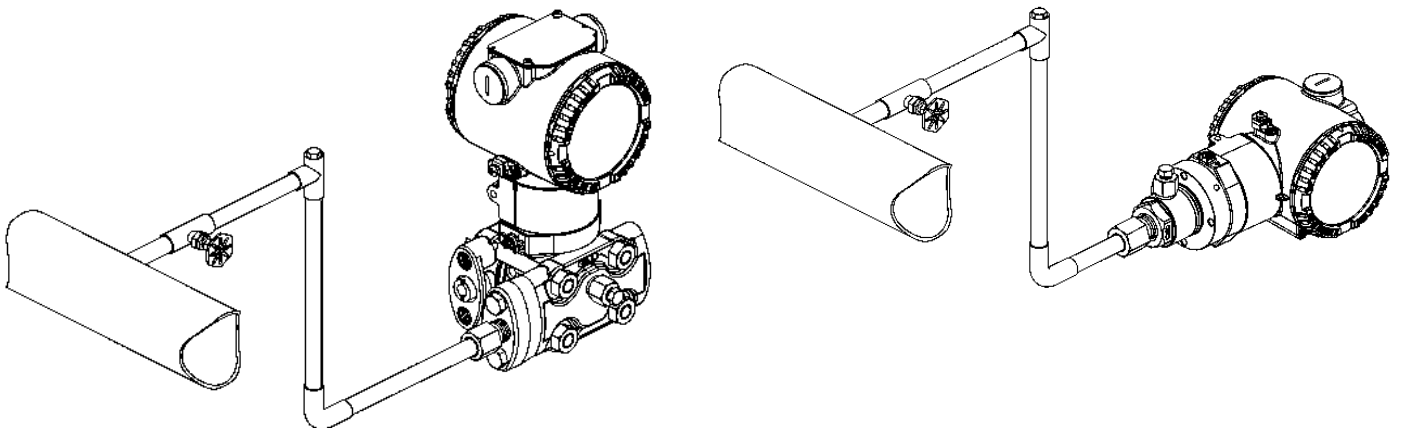

Figure 33: Gauge or absolute pressure measurement of condensable vapor in a pipe with DP and P style transmitter (filling tee installed)

266 Models - HART

Pressure or absolute pressure measurement of a gas in a pipe

- Place the tap at the top or side of the line.
- Mount the transmitter beside or above the tap.
- Connect the transmitter to the pipe.

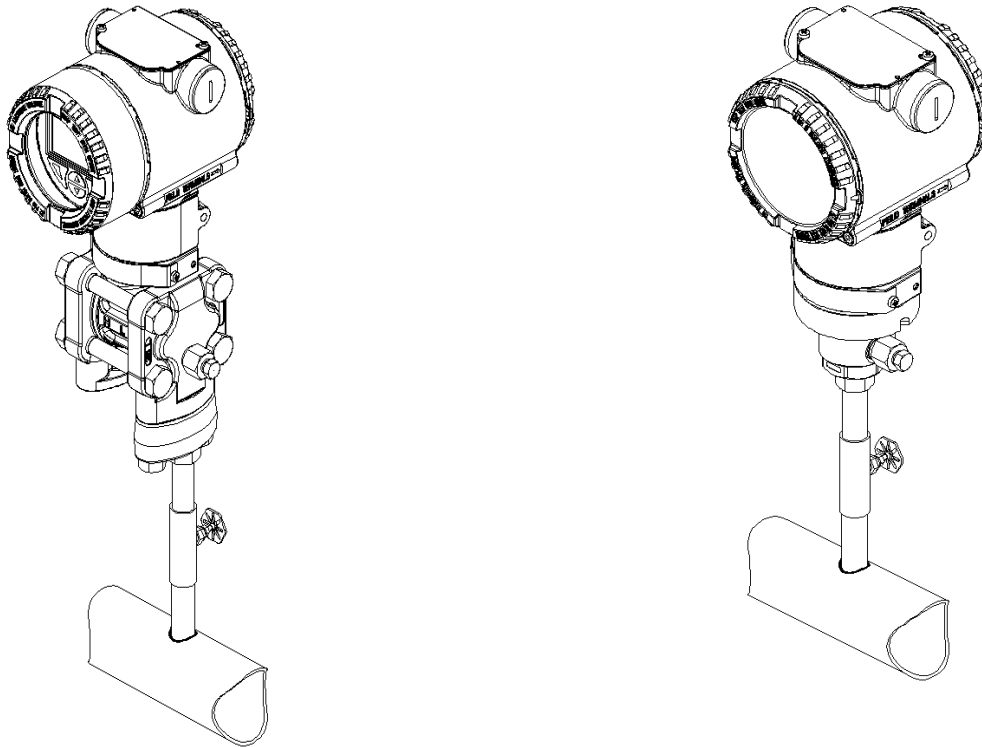

Figure 34: Gauge or absolute pressure measurement of gas in a pipe with DP and P style transmitter

Transmitter wiring



Warning - General risks

Observe the applicable regulations governing electrical installation. Connections must only be established in a dead-voltage state. Since the transmitter has no switch-off elements, overvoltage protection devices, lightning protection, and voltage separation capacity must be provided at the plant (overvoltage/lightning protection is optional). Check that the existing operating voltage corresponds to the voltage indicated on the name plate.

The same lines are used for both the power supply and output signal. In case the surge protection option is present and the transmitter is installed in a Hazardous area, the transmitter has to be power supplied from a voltage source isolated from mains (galvanic separation).

Furthermore the potential equalization for the entire powering cable must be guaranteed since the intrinsic safety circuit of the transmitter is grounded.



Warning - General risks

Electrical shock can result in death or serious injury. Avoid contact with the leads and terminals.

High voltage that may be present on leads can cause electrical shock.



Warning - General risks

Do NOT make electrical connections unless the electrical code designation stamped on the transmitter data plate agrees with the classification of the area in which the transmitter is to be installed. Failure to comply with this warning can result in fire or explosion.

Cable connection

Depending on the design supplied, the electrical connection is established via a cable entry, M20 x 1.5 or 1/2-14 NPT thread, or Han 8D plug (8U) (PROFIBUS PA and FOUNDATION Fieldbus: M12 x 1 or 7/8 plug). The screw terminals are suitable for wire cross sections of up to 2.5 mm² (AWG 14).

i**Important**

With Category 3 transmitters for use in "Zone 2", a qualified cable gland for this type of protection must be installed by the customer (see the section "Hazardous Area Consideration"). An M20 x 1.5 threads is located in the electronics housing for this purpose.

For transmitters with "Flameproof enclosure" (Ex d) type of protection, the housing cover must be secured using the locking screw.

The screw plug that may have been supplied with the transmitter must be sealed at the plant using Molykote DX.

The installer assumes responsibility for any other type of sealing medium used.

At this point, we wish to draw your attention to the fact that increased force will be required to unscrew the housing cover after an interval of several weeks.

This is not caused by the threads, but instead is due solely to the type of gasket.

Analogue output (HART) transmitter wiring

Figure 35: HART transmitter connection scheme

HART hand-held communicator may be connected at any wiring termination point in the loop, providing the minimum resistance is 250 ohm. If this is less than 250 ohm, additional resistance should be added to allow communications. The handheld terminal is connected between the resistor and transmitter, not between the resistor and power source.

Supply requirement

For signal/power connection use twisted, stranded pairs of wiring no 18 to 22 AWG / 0.8 to 0.35mm² \varnothing up to 5,000 feet (1500 meters). Longer loops require larger wire. If a shielded wire is used, the shield should be grounded only at one end, not both ends. In case of wiring at transmitter end, use the terminal located inside the housing marked with the appropriate sign. The 4 to 20 mA dc output signal and the dc power supply to the transmitter are carried from the same pairs of wires. The supply voltage at the transmitter terminals must be between the limits of 10,5 and 42V dc.

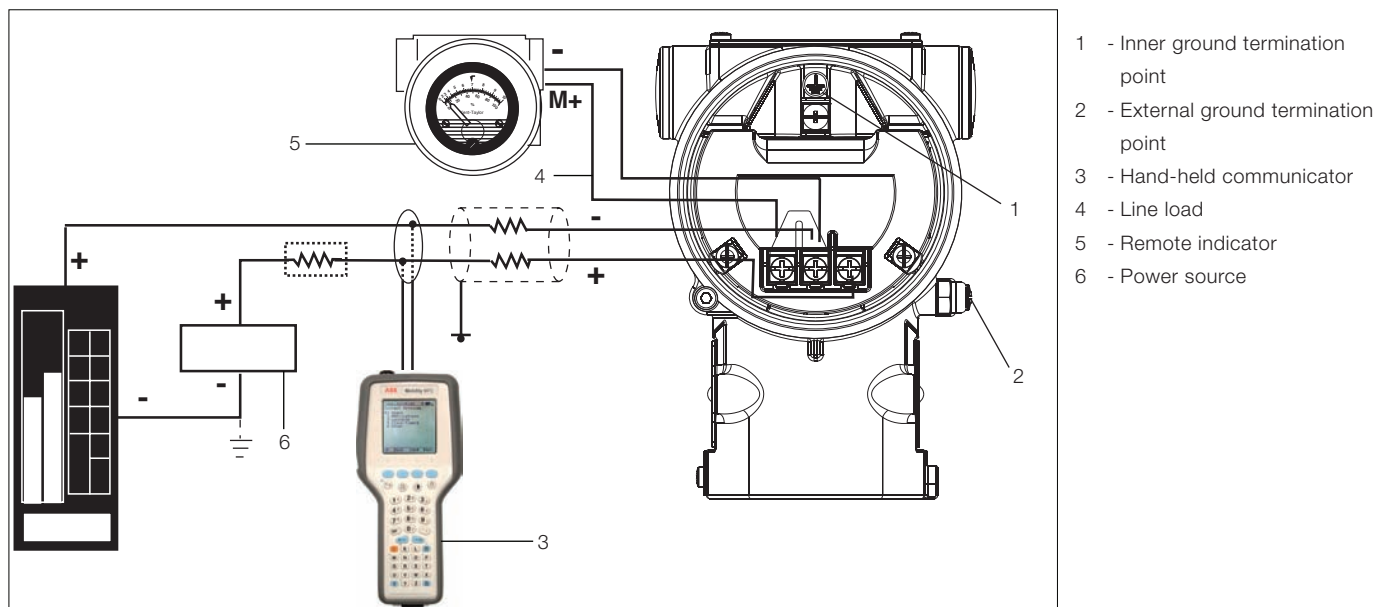
For Ex ia and intrinsically safe (FM, CSA and SAA) approval power supply must not exceed 30 Vdc. In some countries the maximum power supply voltage is limited to a lower value. For maximum power supply voltage please refer to the top identification plate of the transmitter.

266 Models - HART

The actual possible line length of the electrical circuit depends on the total capacitance and resistance, and can be estimated using the following formula:

$$L = \frac{65 \times 10^6}{R \times C} - \frac{C_f + 10000}{C}$$

Where:

L = Line length in meters

R = Total resistance in Ω (ohms)

C = Line capacitance in pF/m

C_f = Maximum internal capacitance of the HART field devices located in the circuit, in pF

Avoid routing cables with other electrical cables (with inductive load, etc.) or near large electrical equipment.

Wiring procedure

Follow these steps to wire the transmitter:

- Remove the temporary plastic cap from one of the two electrical connection ports located at both sides in the upper part of the transmitter housing.
- These connection ports may have a 1/2 inch internal NPT or M20 threads. Various adaptors and bushings can be fitted to these threads to comply with plant wiring (conduit) standards.
- Remove the housing cover of the “field terminals” side. See the indication on the label on top of the housing. In an Explosion-Proof/Flame-Proof installation, do not remove the transmitter covers when power is applied to the unit.
- Run the cable through the cable gland and the open port.
- Connect the positive lead to the + terminal, and the negative lead to the – terminal.
- Plug and seal the electrical ports. Make sure that when the installation has been completed, the electrical ports are properly sealed against entry of rain and/or corrosive vapors and gases.



Warning - General risks

Cable, cable gland and unused port plug must be in accordance with the intended type of protection (e.g. intrinsically safe, explosion proof, etc.) and degree of protection (e.g. IP6x according to IEC EN 60529 or NEMA 4x). See also the addendum for “EX SAFETY” ASPECTS AND “IP” PROTECTION. In particular, for explosion proof installation, remove the red temporary plastic cap and plug the unused opening with a plug certified for explosion containment

- If applicable, install wiring with a drip loop. Arrange the drip loop so the bottom is lower than the conduit connections and the transmitter housing.
- Put back the housing cover, turn it to seat O-ring into the housing and then continue to hand tighten until the cover contacts the housing metal-to-metal. In Ex-d (Explosion Proof) installation, lock the cover rotation by turning the set nut (use the 2mm Allen key supplied with the instrument).

Electrical connection via connectors

Harting connector (HART output versions) on DIN housing

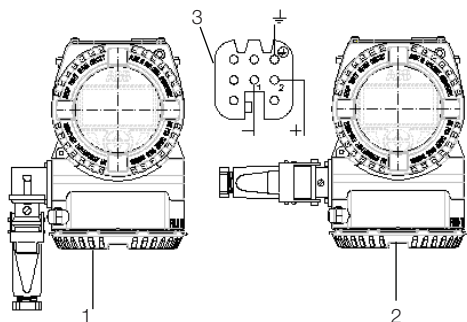

- 1 - DIN Housing with Harting angle connector
- 2 - DIN Housing with Harting straight connector
- 3 - Harting Han 8D socket insert for mating plug supplied (view of sockets)

Figure 36: Harting HAN straight and angle connection connectors

Assembling and connecting the socket connector

The socket connector for connecting the cable is supplied unassembled as an accessory for the transmitter.

- The contacts (2) are crimped or soldered onto the cable ends (wire cross section of 0.75 ... 1 mm² (AWG 18 ... AWG 17)), from which approx. 1.5 ... 2 cm (0.59 ... 0.79 inch) of the sleeve and approx. 8 mm (0.32 inch) of the insulation have been stripped; they are then inserted into the socket (1) from the rear.
- Slide the set screw (6), clamping ring (5), gasket (4), and housing (3) onto the cable in the order indicated before assembly (you may have to adjust the gasket (4) to fit the cable diameter).



Important

Before you press the contacts completely into the socket, check the connection points again. Incorrectly inserted contacts can be removed by using a press-out tool (part no.: 0949 813), or a standard ballpoint pen as a makeshift tool. Please observe the connection diagram included with the plug.

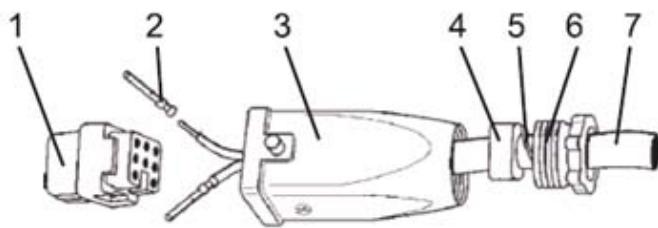

- 1 - Socket
- 2 - Contact
- 3 - Housing
- 4 - Gasket (can be cut)
- 5 - Clamping ring
- 6 - PG 11 set screw
- 7 - Cable (diameter 5 - 11 mm or 0.20 - 0.43 inch)

Figure 37: Socket connector components

Grounding

A terminal is available on both the outside of the housing and in the plug for grounding (PE) the transmitter. Both terminals are electrically connected to one another.

Protective Grounding

All transmitters are supplied with an external ground connection for protective grounding.

Wire this ground connection to a suitable earth ground. For a transmitter measuring loop an earth ground should maintain a resistance of 5 ohms or less.

Use a heavy duty conductor, at least 15 AWG / 1,6 mm² Ø.

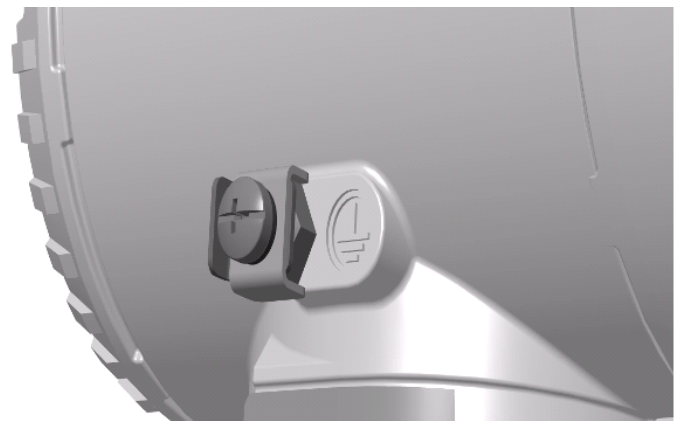

Figure 38: Ground connection on transmitter housing



Warning - General risks

A protective grounding connection is absolutely necessary to insure personnel protection, to protect against surge (in case of installation of this option) and to prevent explosions in potentially explosive environment.

Integrated lightning protection (optional)

The transmitter housing must be connected using the grounding terminal (PA), by means of a short connection with the equipotential bonding. Equipotential bonding minimum diameter of 4 mm² (AWG 12) is required throughout the cable routing area.

In the case of transmitters with integrated lightning protection (optional), the intrinsically safe circuit is connected to the equipotential bonding for safety reasons.



Important

Test voltage withstand capability can no longer be ensured when this protective circuit is used.

266 Models - HART

Commissioning

Once the transmitter has been installed, it is put into operation by switching on the operating voltage.

Check the following before switching on the operating voltage:

- Process connections
- Electrical connection
- The impulse line/s and the measuring chamber of the measuring equipment must be completely filled with the measuring medium.

The transmitter can then be put into operation. To do this, the shut-off valves must be actuated in the following sequence (in the default setting, all valves are closed).

(Differential models) 266Dx or 266Mx

- Open the shut-off valves on the pressure tap connection (if present).
- Open the pressure equalization valve of the manifold.
- Open the positive shut-off valve (on the manifold)
- Open the negative shut-off valve (on the manifold)
- Close the pressure equalization valve.

To put the transmitter out of operation, carry out the steps in reverse order.

(Gauge & Absolute models) 266Gx, 266Ax, 266Hx, 266Nx, 266Px, 266Vx, 266Rx

- Open the shut-off valve on the pressure tap connection (if present).
- Open the positive shut-off valve.

To put the transmitter out of operation, carry out the steps in reverse order.



Important

For the absolute pressure transmitters model 266AS, 266NS, 266RS or 266VS with sensor range C, F or G, please be aware that the measuring equipment will have been overloaded by the atmospheric pressure due to the long periods of transport and storage involved.

For this reason, you will need to allow a starting time of approx. 30 minutes for 266Vx, 266Rx and 266Nx models and approx. 3 hours for 266Ax models after commissioning, until the sensor has stabilized to such an extent that the specified accuracy can be maintained.

If, when using "intrinsically safe" transmitters, an ammeter is connected to the output circuit or a modem is connected in parallel while there is a risk of explosion, the sums of the capacitances and inductances of all circuits, including the transmitter (see EC-type-examination certificate) must be equal to or less than the permissible capacitances and inductances of the intrinsically safe signal circuit (see EC-type-examination certificate for the supply unit).

Only passive or explosion-proof devices or indicators may be connected.

If the output signal stabilizes only slowly, it is likely that a large damping time constant has been set on the transmitter.

Analogue and HART Communication models

If the pressure applied falls within the values indicated on the name plate, the output current will be between 4 and 20 mA.

If the pressure applied falls outside the set range, the output current will be between 3.5 mA and 4 mA if the range is undershot or between 20 mA and 22.5 mA if the range is overshoot (depending on the respective configuration).

Standard setting for normal operation

3.8 mA / 20.5 mA

In order to prevent errors in flow rate measurements (266Dx and 266Mx) in the lower range, it is possible to set a "cut off point" and/or a "lin./sq. root transition point" via the optional LCD integral displays or via the graphical user interface (DTM).

Unless otherwise specified, the "lin./sq. root transition point" is set to 5% and the "cutoff" to 6% of the flow rate end value by the manufacturer; A current that is < 4 mA or > 20 mA may also indicate that the microprocessor has detected an internal error. In this case the alarm output can be configured both via the local LCD or via an external Hart hand held terminal (ABB 691HT, DHH801 etc) or via a DTM based configuration tool (Asset Vision).

Standard setting for error detection (alarm)

21 mA

The graphical user interface (DTM) or the LCD integral display (if installed) can be used to diagnose the error.



Important

A brief interruption in the power supply results in initialization of the electronics (program restarts).

Write Protection

Write protection prevents the configuration data from being overwritten by unauthorized users. If write protection is enabled, the “Z” and “S” buttons are disabled. However, it is still possible to read out the configuration data using the graphical user interface (DTM) or another, similar communication tool. The control unit may be leaded if required.

Write protection is activated as follows (also refer to the symbols on the plate):

- First, use a suitable screwdriver to press the switch down fully.
- Then turn the switch clockwise by 90°.

i **Important**
To deactivate the switch, push it down slightly and then turn counterclockwise by 90°.

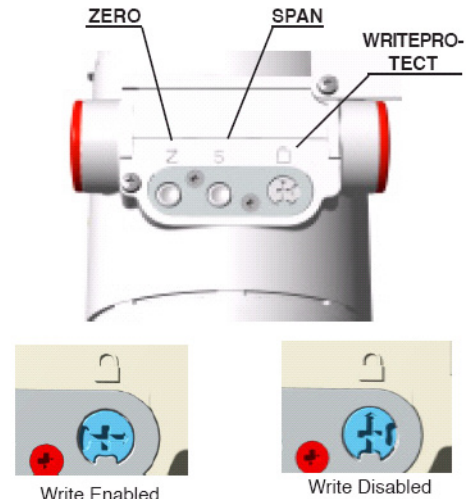

Figure 39: Write-protection pushbutton

Correcting the lower range value / zero shift

During installation of the transmitter, transmitter, zero shifts caused by mounting (e.g., a slightly oblique mounting position due to a remote seal, etc.) may occur; these must be corrected.

i **Important**
The transmitter must have reached its operating temperature (approx. 5 min. after startup, if the transmitter has already reached the ambient temperature) in order to perform zero shift correction. The correction must be made at dp (or p) = 0.

i **Important**
The button unit must be available for this purpose.
Operating the buttons using a magnetic screwdriver is not permitted because it may generate some interferences with the magnetic pickup system.

Set lower range value

- Apply the lower range value pressure (4 mA) from the process or from a pressure transducer. The pressure must be stable and applied with a high level of accuracy $\ll 0.05\%$ (observing the set damping value).
- Press the “Z” button on the pressure transmitter for few seconds. The output signal will be set to 4 mA. The span will remain unchanged.

i **Important**
A lower range value set using this method will be stored in the non-volatile memory < 25 s (HART), when the “Z” button is pressed

Correct the zero shift

The zero shift caused by the installation may be cancelled in different ways:

- Pressing the Z button (under the identification plate on the top of the transmitter) for few seconds will cause the output to go at 4 mA.
- It is also possible to align the digital PV value to zero.

To accomplish it raise the dip sw. 3 on the communication board to the up (1) position and press the external zero button.

This functionality will align the PV digital value to 0 and if the calibrated span it is zero based, the output will go at 4 mA.

- Using the optional LCD keypad (“Configuration of the pressure transmitter using the integral LCD HMI” for further information).

i **Important**
The procedure described in “1” above does not affect the physical pressure shown; it only corrects the analog output signal.
For this reason, the analog output signal may differ from the physical pressure (PV Value) shown on the digital display or the communication tool. To avoid this discrepancy, correct the zero position shift (zero shift) via the PV-BIAS/OFF-SET functionality described in point “2” above.

266 Models - HART

Installing/Removing the external pushbuttons

- Loosen the screws that fix the nameplate plate and slide the plate to gain access to the local adjustments.
- Loosen the pushbuttons assembly screws (1) holding down the plastic element which is spring loaded.
- Remove the gasket (3) which is positioned below the pushbutton plastic cover (2).
- The three pushbuttons (4) and the relevant springs (5) can now be removed from their seat.

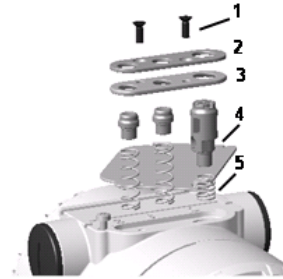

Figure 40: External pushbutton assembly components

Installing/Removing the LCD display

- Unscrew the housing cover of the communication board/LCD side.



Important

With an Ex d / Flameproof design, please refer to the section "Securing the housing cover in flameproof areas".

- Attach the LCD display. Depending on the mounting position of the pressure transmitter, the LCD display may be attached in four different positions.

This enables $\pm 90^\circ$ or $\pm 180^\circ$ rotations.



Important

Retighten the housing cover until it is hand-tight.
If necessary, refer to the section "Securing the housing cover in flameproof areas".



Figure 41: Windowed front cover and LCD display

Securing the housing cover in flameproof areas

Each of the front faces of the electronics housing features a locking screw (hex-head socket screw) on the bottom side.

- Install the housing cover to the housing by hand-tightening it.
- Turn the locking screw counterclockwise to secure the housing cover. This involves unscrewing the screw until the screw head stops at the housing cover.

Operation

Local pushbuttons functionality

266 transmitters allow local adjustments via the on-board non intrusive pushbuttons.

The pushbuttons are located under the identification nameplate. To gain access to the local adjustments release the fixing screws of the nameplate and rotate clockwise the identification plate.

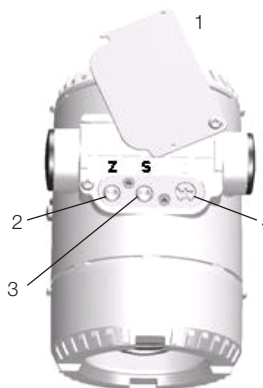

- 1 - Identification nameplate
- 2 - Zero pushbutton
- 3 - Span pushbutton
- 4 - Write-protection pushbutton



Warning - Potential damage to parts

Operating the control buttons with a magnetic screwdriver is not permitted.

Figure 42: Pushbutton functionalities

Factory settings

Transmitters are calibrated at the factory to the customer's specified measuring range. The calibrated range is provided on the name plate whereas the tag number on the additional tag plate.

The calibrated range and tag number are provided on the name plate. If this data has not been specified, the transmitter will be delivered with the following configuration:

Parameter	Factory setting
Lower Range Value (LRV) (4 mA)	Zero
Upper Range Value (URV) (20 mA)	Upper Range Limit (URL)
Output transfer function	Linear
Damping	1 second
Transmitter failure (alarm)	Upscale (21.8 mA)
Optional LCD HMI scale	1 line PV and output signal bargraph



Important

Every of the configurable parameters here on the left can easily be modified either via the optional LCD HMI, with an HART handheld terminal or a compatible software solution. Information regarding flange type and material, O-ring materials, and filling liquid type is stored inside the non-volatile memory of the device.

Configuration types

Pressure transmitters can be configured as follows:

- Configuration of the parameters for the lower and upper range values (via Zero and Span pushbuttons), without an integral LCD HMI.
- Configuration of the pressure transmitter using the integral LCD HMI (menu-controlled)
- Configuration with a handheld terminal
- Configuration using a PC/laptop via the graphical user interface (DTM)

Configuring the transmitter without an integral LCD HMI

The “lower range value” and “span” parameters can be set directly on the transmitter using the External pushbuttons.

The transmitter has been calibrated by the manufacturer based on the order information. The tag plate contains information on the “lower range value” and “upper range value” set. In general, the following applies:

The first pressure value (e.g., 0 mbar) is always assigned to the 4 mA signal (or 0%), while the second pressure value (e.g., 400 mbar) is always assigned to the 20 mA signal (or 100%). To change the transmitter ranging apply the pressure for the “lower range value” and “upper range value” to the measuring equipment. Make sure that the measuring limits are not exceeded.



Important

Reducing station with adjustable pressure and reference displays can be used as pressure generators.

When making the connection, please ensure that there are no residual fluids (for gaseous testing materials) or air bubbles (for fluid testing materials) in the impulse lines, since these can lead to errors during inspection. Any potential measuring error for the pressure generator should be at least three times smaller than the desired measuring error for the transmitter. It is recommended that the damping is set to 1 second.



Important

In case of the 266 transmitter for absolute pressure (266Vx, 266Rx, 266Ax and 266Nx) with a measuring range less than or equal 650 mbar abs., please be aware that the measuring equipment will have been overloaded by the atmospheric pressure due to the long periods of transport and storage involved. For this reason, you will need to allow a starting time of approx. 30 minutes for 266Vx, 266Rx and 266Nx models and 3 hours for 266Ax models after commissioning, until the sensor has stabilized to such an extent that the specified accuracy can be maintained.

LRV and URV configuration (4 ... 20 mA ranging)

- Apply the pressure for the “lower range value” and wait approx. 30 s until it has stabilized.
- Press the “Z” button. This sets the output current to 4 mA.
- Apply the pressure for the “upper range value” and wait approx. 30 s until it has stabilized.
- Press the “S” button. This sets the output current to 20 mA.
- If required, reset the damping to its original value.
- Record the new settings. The respective parameter will be stored in the non-volatile memory 10 seconds after the “Z” or “S” button is last pressed.

266 Models - HART



Important

This configuration procedure only changes the 4 ... 20 mA current signal; it does not affect the physical process pressure (PV value) also shown on the digital display or user interface. To avoid potential discrepancies, you can use follow the procedure below. After performing a correction, you must check the device configuration.

Correction of zero shift caused by installation with PV Zero Bias / Offset

- Raise the dip switch 3 in 1 (up) position
- Press the “Z” button. This sets the output current to 4 mA, the digital PV value will be set to 0 (zero)
- To reset the PV zero bias setting, press the “S” button.



Important

When the transmitter has been rezeroed following the above procedure, a zero bias/offset value is applied and stored in the transmitter memory.

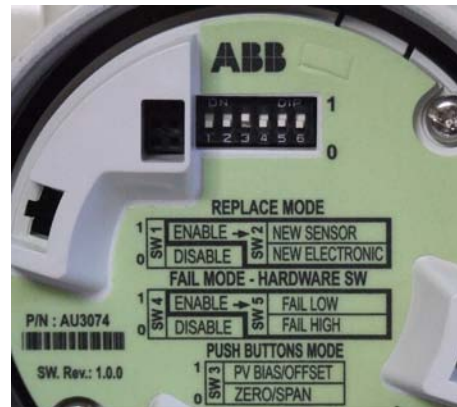

Figure 43: Communication board overview

Configuration of the pressure transmitter using the optional integral LCD HMI (menu-controlled)

The integral LCD HMI is connected on the 266 communication board. It can be used to visualize the process measured variables as well as to configure the display and the transmitter.

In addition, diagnostic information is provided. To access the functionality of the HMI an activation procedure needs to be carried out. The keypad activation procedure is different between the TTG (Trough The Glass) version and the conventional HMI.

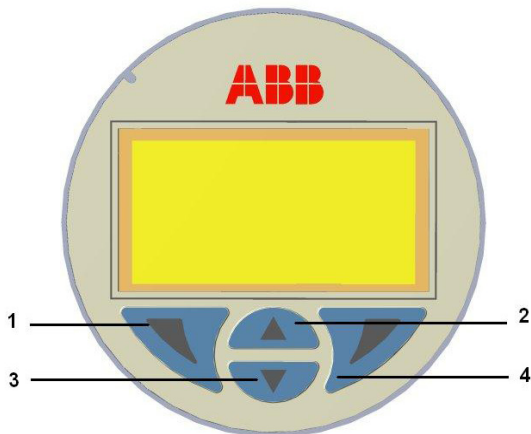

Figure 44: Display keypad

The keys (1), (4), (2) and (3) are available for the menu-controlled configuration.

- The menu/submenu name is displayed above in the LCD display.
- The number/line of the currently selected menu item is displayed in the upper right of the LCD display.
- A scroll bar is located on the right edge of the LCD display which shows the relative position of the currently selected menu item within the menu.
- Both of the keys (1) and (4) can have various functions. The meaning of these buttons is displayed below in the LCD display above the respective button.
- You can browse through the menu or select a number within a parameter value using both keys (2) and (3). The button (4) selects the desired menu item.

Button (1) functionalities	Meaning
Exit	Exit menu
Back	Back one submenu
Cancel	Exit without saving the selected parameter value
Next	Select next position for entering numerical values or letters

Button (4) functionalities	Meaning
Select	Select submenu/parameter
Edit	Edit parameter
Ok	Save selected parameter and display stored parameter value

LCD (L1 option) activation considerations

Gain access to the display by unscrewing the windowed cover. Please observe the Hazardous area prescription before proceeding with the cover removal. For activation, see instructions below.

Through The Glass (TTG) (L5 option) activation considerations

The TTG technology allows the user to activate the keypad on the HMI without the need of opening the windowed cover of the transmitter. The capacitive pick-ups will detect the presence of your finger in front of the respective button activating the specific command. At the transmitter power-on the HMI automatically calibrate its sensitivity, it is mandatory for the proper functioning of the TTG HMI that the cover is properly tightened at power-on.

In case the cover has been removed to access the communication board, it is recommended to power off and power-on again the transmitter once the windowed cover has been set in place and properly tightened.

Activation procedure for TTG (L5) and LCD (L1)

The HMI features 4 pushbuttons (see figure here above) that allow the navigation through the various functions.

- Press simultaneously the buttons (2) and (3) until two icons will appear at the bottom corners of the display.
- Press the button (4) under the right icon within one second. to access the HMI menu or press the left button (1) to access the instantaneous diagnostic messages.

HMI menu structure

The HMI menu is divided in the following sections which can be selected by acting on the keys (2) and (3), once on the display the desired sub-menu icon will be visualized, confirm your selection with the [SELECT] key (4)

Follow the instruction on the screen to perform the configuration of the different parameters.

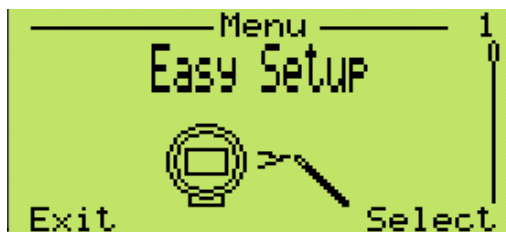

This menu allows the verification and the parameterization of the basic configuration of the 266 pressure transmitter. The menu driven structure will guide you to the choice of the interface language, the tag number configuration, the engineering units, the URV and LRV (Upper range value and lower range value), the transfer function (linear or square root) the damping time, the auto set zero (set the input measured value to 4 mA and the PV value to 0), the display visualization mode (the value that need to be visualized on the LCD).

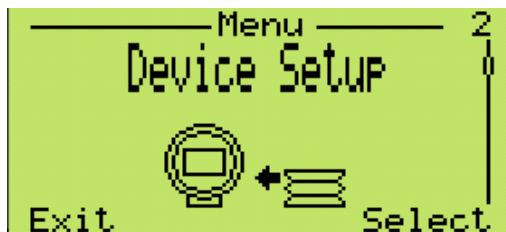

This menu allows the verification and the parameterization of the entire device. The menu driven structure includes the write protection enabling, process variable settings (unit, LRV and URV), transfer function selection (linearization type and low flow cut-off) and output scaling (unit according to the measurement and LRV/URV). The last selectable sub-menu allows user to reset all the parameters to the default configuration.

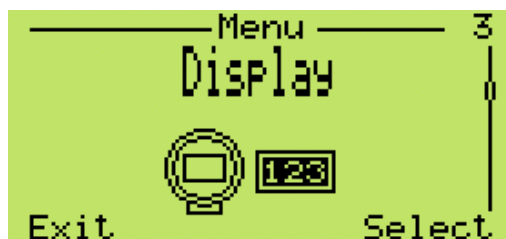

This menu allows the set-up of different functions relevant to the display itself. The menu driven structure will guide you through the choice of some functional aspects as the display language and contrast. Moreover, it is possible to choose in details what you want to see on the display: one or two lines with or without bargraph. Inside this menu there is the possibility of setting a protection password (security) and the display scaling (linearization type, unit, LRV, URV). Display revision number available.

266 Models - HART

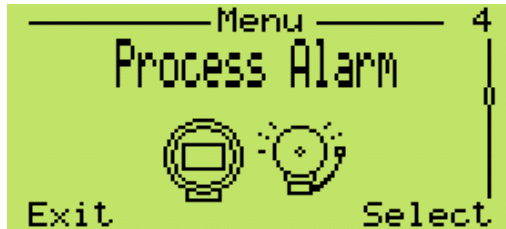

This menu allows the parameterization of the process alarm. The menu driven structure will guide you through the choice of the fail safe functions such as the saturation limits and the fail level (upscale or downscale).



This menu allows the local calibration of the instrument. The menu driven structure will guide you through the choice of pressure sensor trimming (low or high), the output setting (set to 4 or 20 mA) and at the end you can reset these parameters (to factory sensor trimming, to user sensor trimming or to factory output trimming).

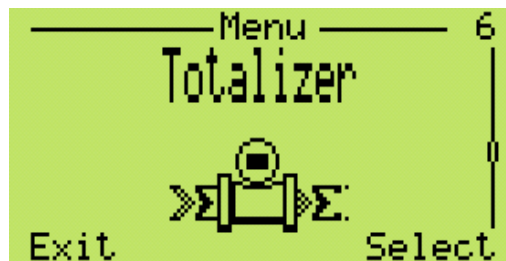

This menu allows the set-up of the on-board totalizer. The menu driven structure will guide you through the selection of the totalizer input parameters (run/stop totalization), the choice of the totalization mode (normal, batch, forward/reverse, forward + reverse and forward – reverse), the configuration (unit and conversion factor of totalizer 1 and 2). Furthermore, it is possible to set up the values of the batch totalizer (count direction, present value and reload). User will be able to add/change/delete the password as well as to reset all totalizers.

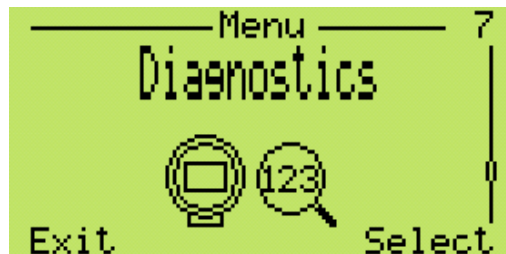

This menu allows you to monitor diagnostics messages related to pressure variable, output current, output percentage, scaled output, static and sensor pressure. The menu driven structure will also guide you through the loop test (set 4 and 20 mA and set the output value).



This menu gives you all information about the device. The menu driven structure will show you what is the sensor type, the hardware and software revisions, the high and low sensor limits as well as the minimum applicable span.



The last section of this structured and driven menu gives you the possibility of changing the communication tag and the MULTI-DROP mode with HART address numbers of the device.

Easy Set-up

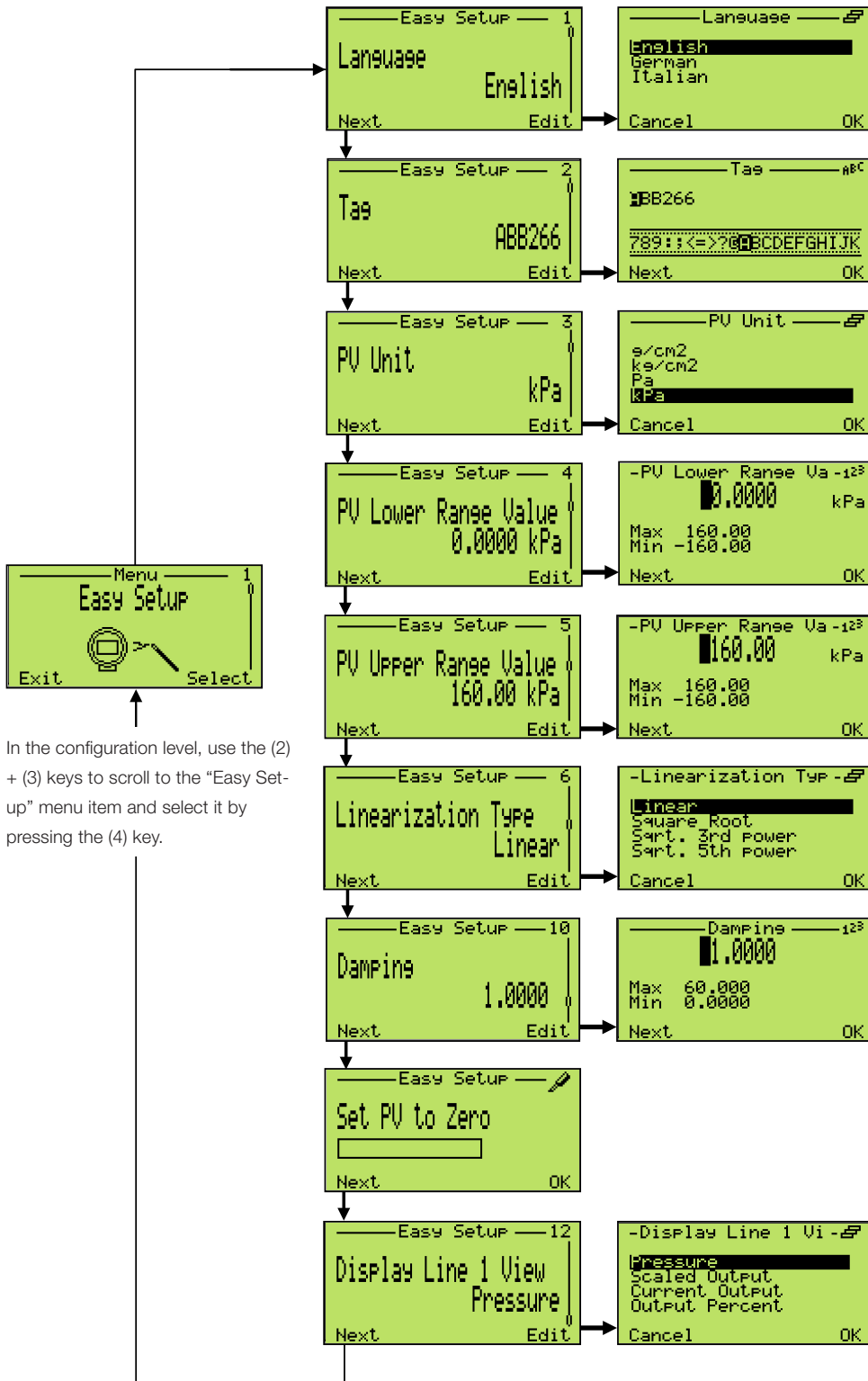

In the configuration level, use the (2) + (3) keys to scroll to the "Easy Set-up" menu item and select it by pressing the (4) key.

Press key (4) and select the language. After entering the settings, press key (1) to move to the next menu item.

Once in the alphabetic menu use Next (1) key to position the cursor on the character that you want to change. Scroll the character list with (2) + (3), once on the selected one press "next" key (1) once completed press "ok" (4).

Press the (4) key Scroll the eng. units list with (2) + (3) and select with (4) key. Press the (1) key to move to the next menu item.

Press the (4) key and set LRV value. After entering the settings, press the (1) key to move to the next menu item.

Press the (4) key and set LRV value. After entering the settings, press the (1) key to move to the next menu item.

Press the (4) key and select the transfer function from the list with (2) + (3). After entering the settings, press the "ok" (1) key to move to the next menu item.

Press the (4) key and set the damping. After entering the settings, press the (1) key to move to the next menu item.

This function set to zero the PV value and to 4 mA the analogue output. Simply press "ok" (4) key to activate the PV to zero function. Press Next (1) key to move to the next menu item.

This function allows the selection of the LCD visualization. Select between the list and confirm with "ok" (1) key.

266 Models - HART

Device Set-up

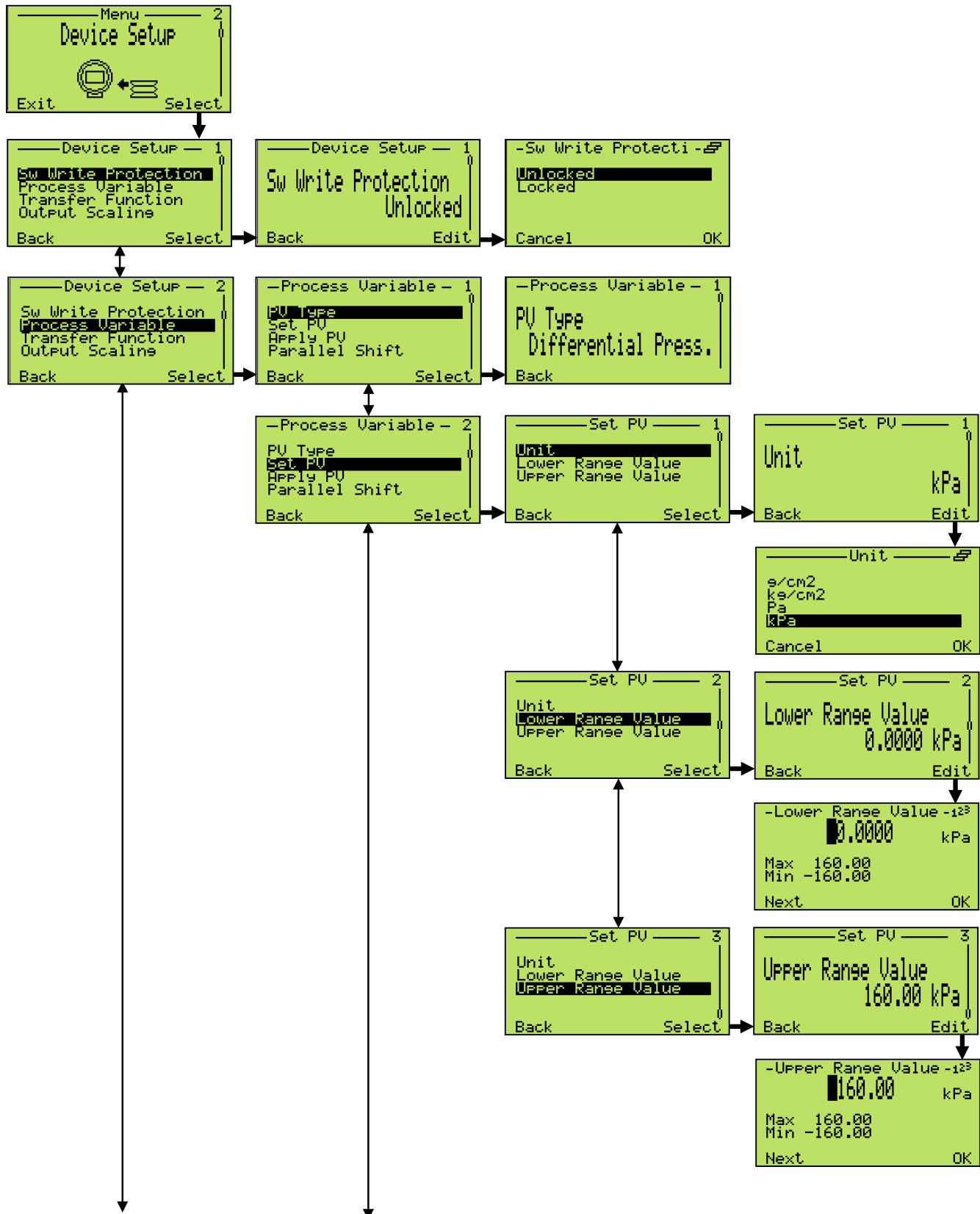

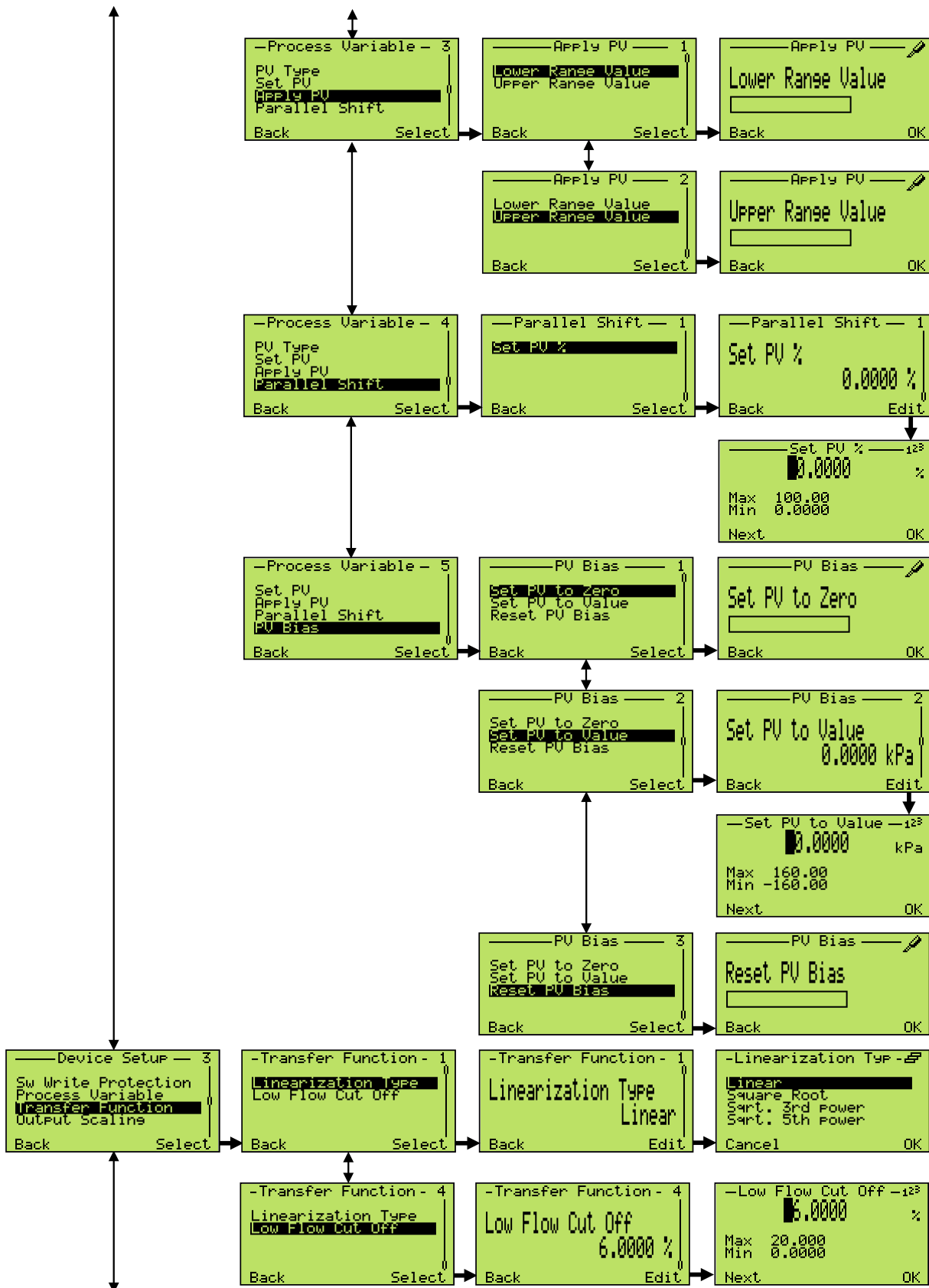

266 Models - HART

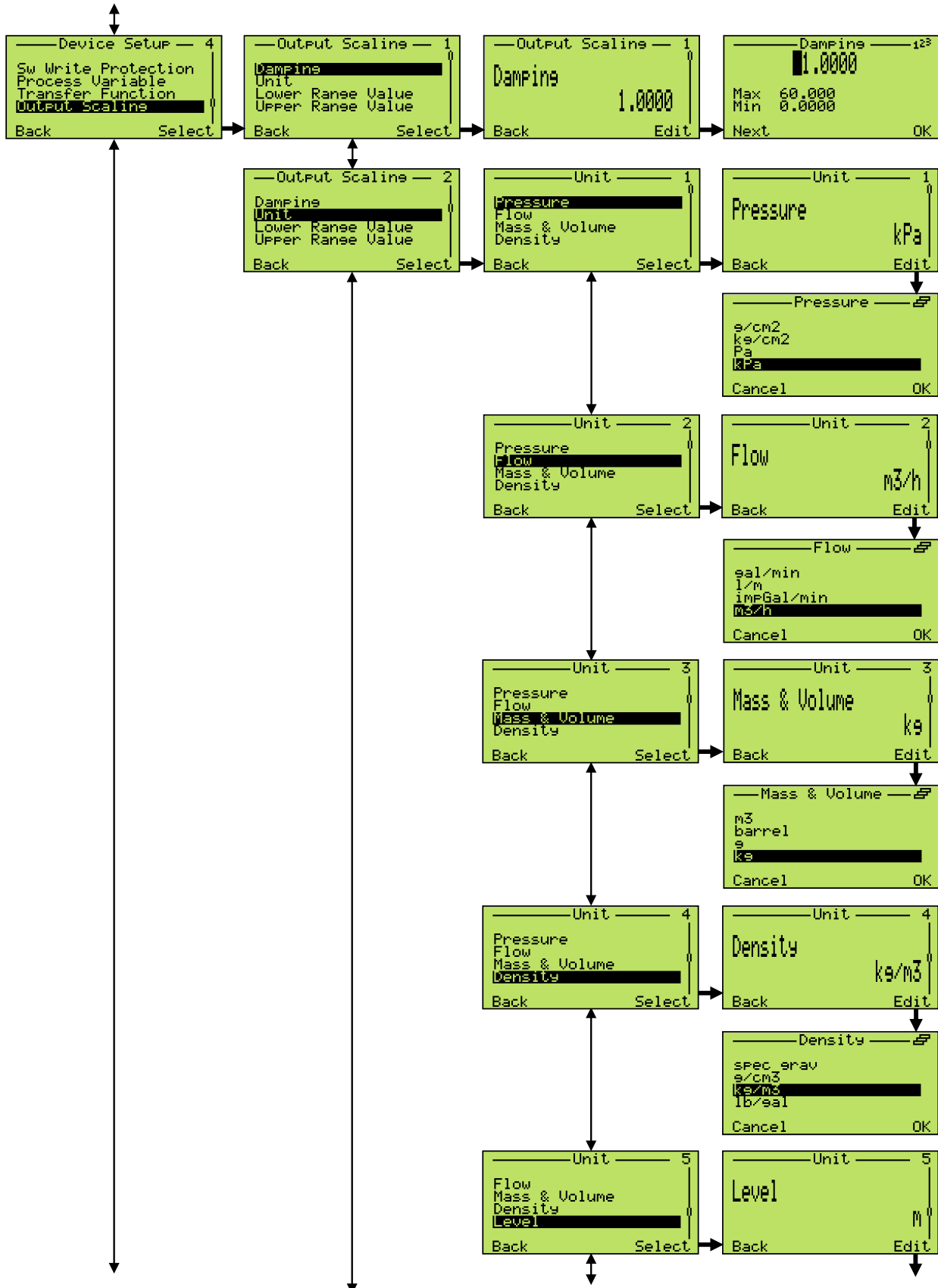

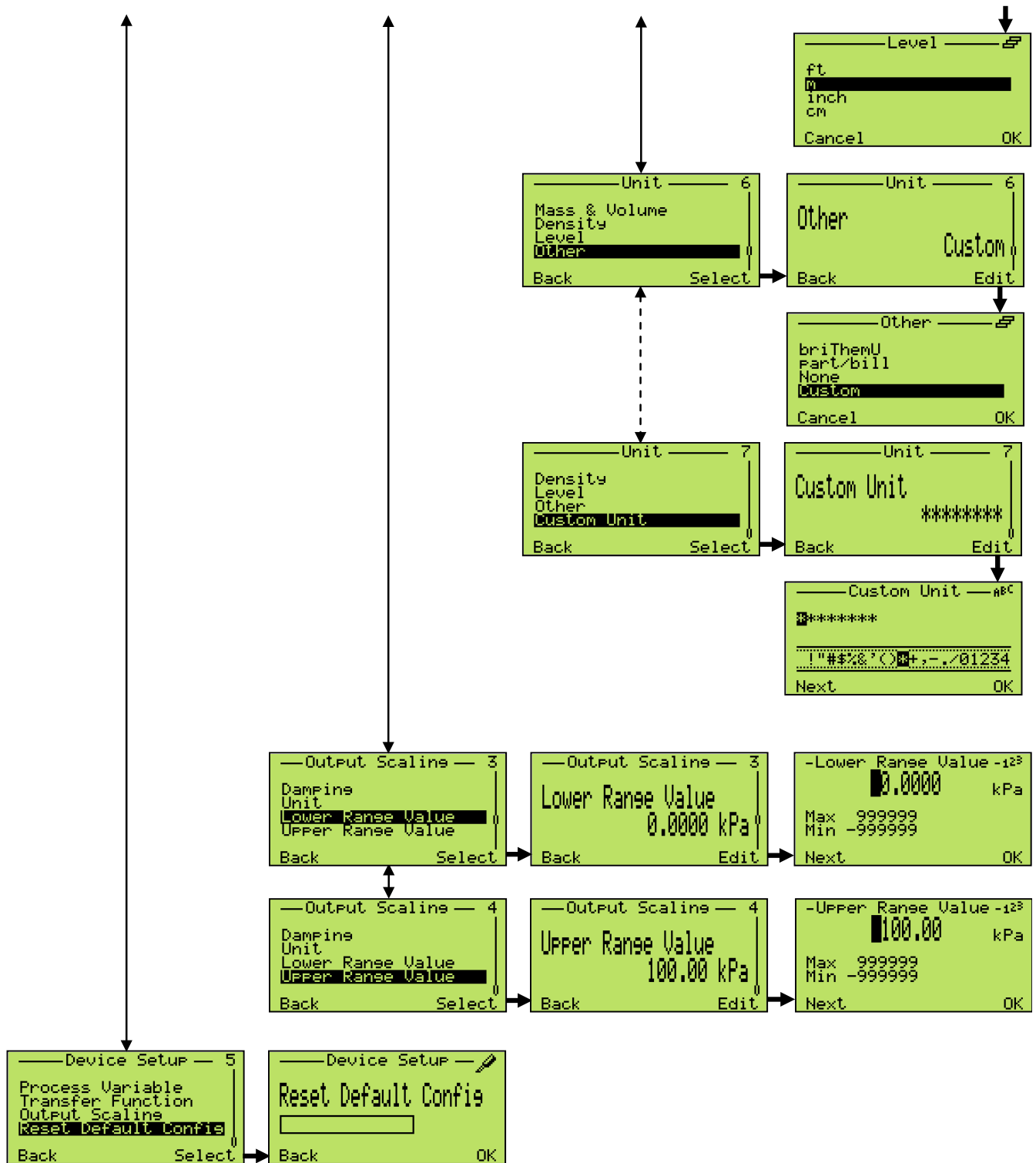

266 Models - HART

Display

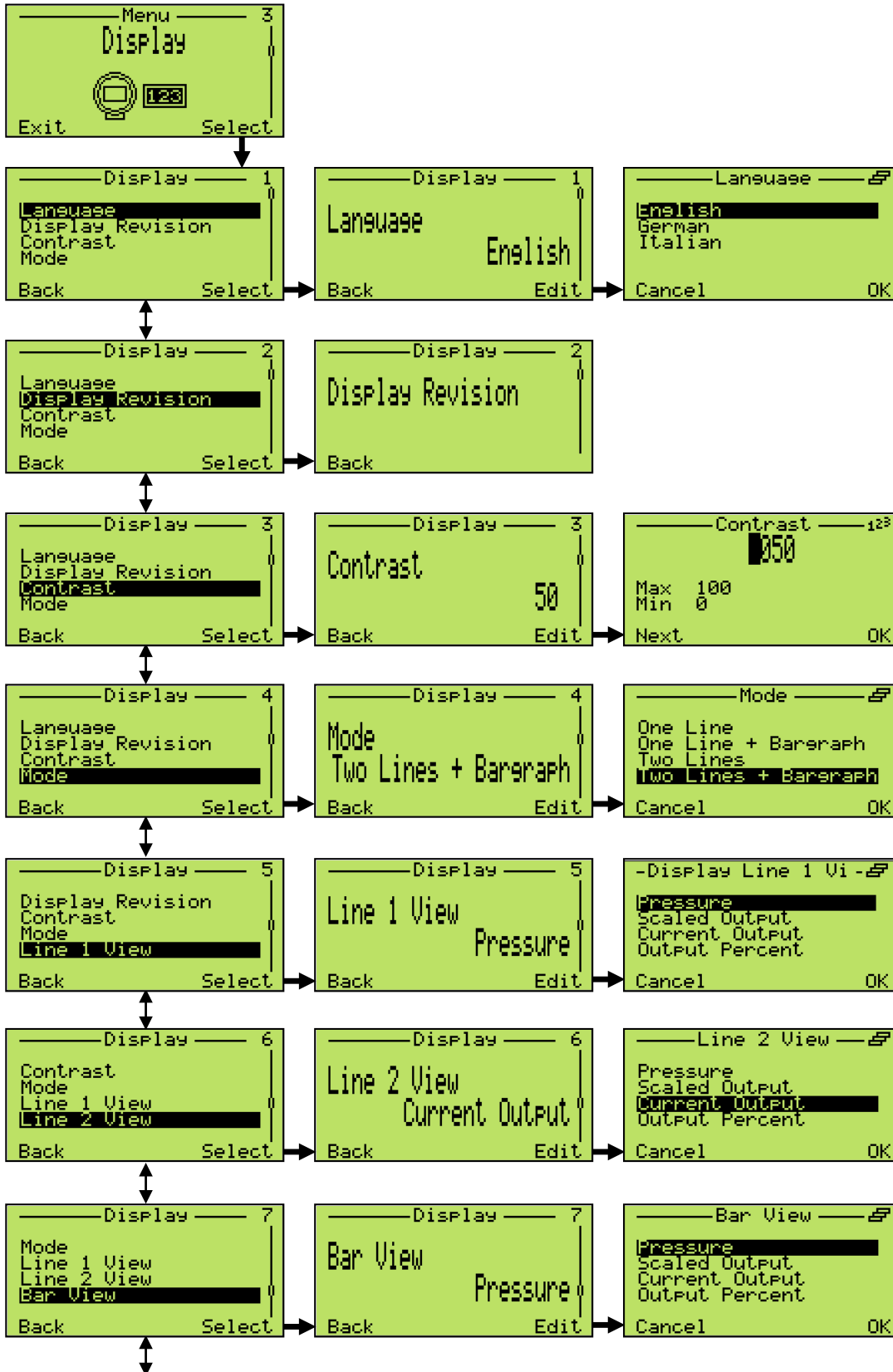

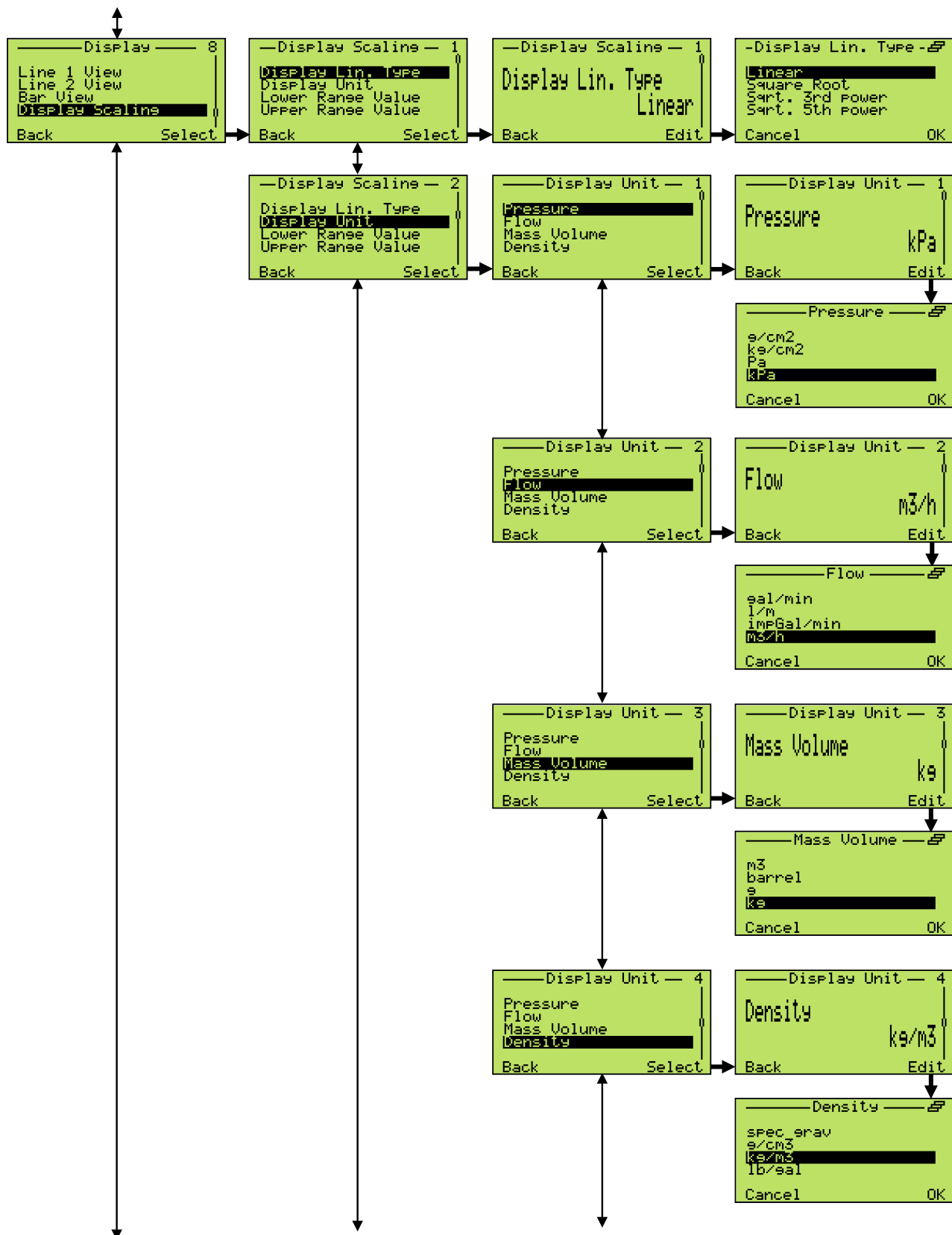

266 Models - HART

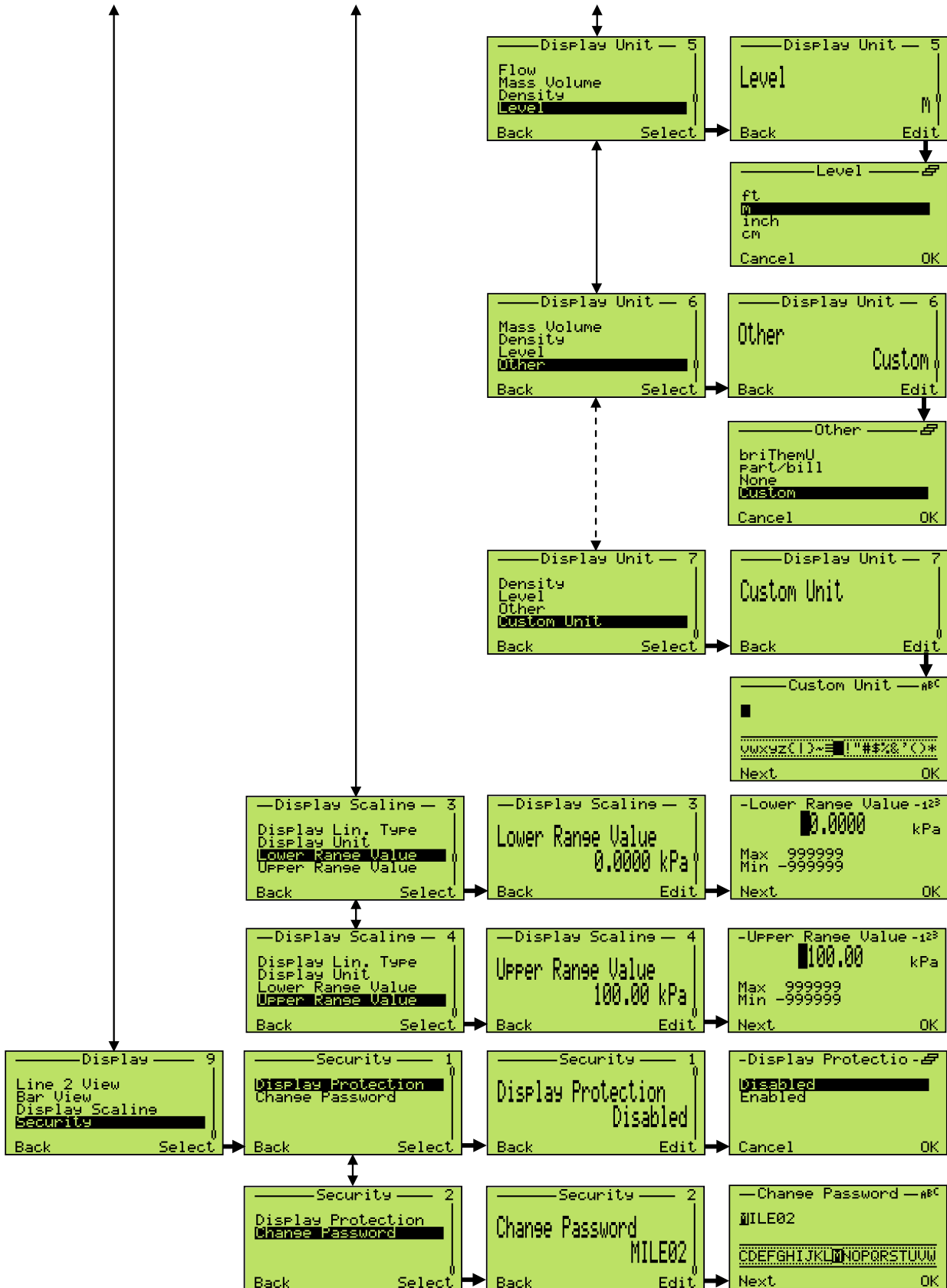

Process Alarm

This menu allows the complete configuration of the analogue output in case of saturation and alarm. The output signal will range from 4 to 20 mA in case the process variable is within the calibrated span limits. In case the process variable (PV) will be below the LRV (lower range value) the signal will be driven to the "Low Saturation" limit (which is configurable), in case the PV will be above the URV (upper range value) the signal will be driven to the "High Saturation" limit (which is configurable too). In case the transmitter diagnostic detects a failure the signal will be driven upscale or downscale according to the user preferences (the failure direction is selected via the dip switch 4 and 5 on the communication board). The exact value to which the signal will be driven can be configured via the above menu (Alarm limits). As a convention the Low Alarm limit must be < the Low Saturation limit and the High Alarm limit must be > than the High Saturation limit.

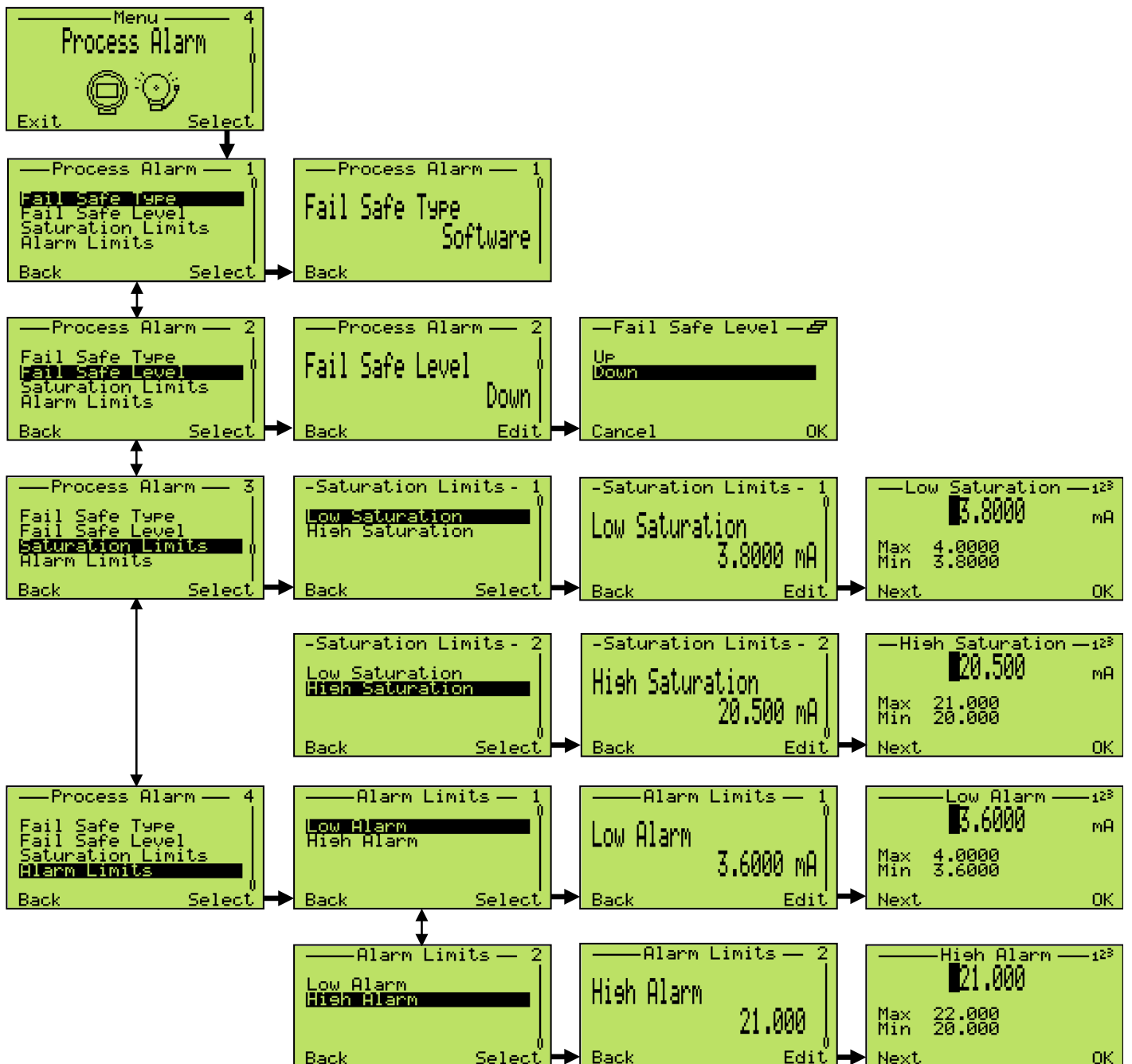

266 Models - HART

Calibrate

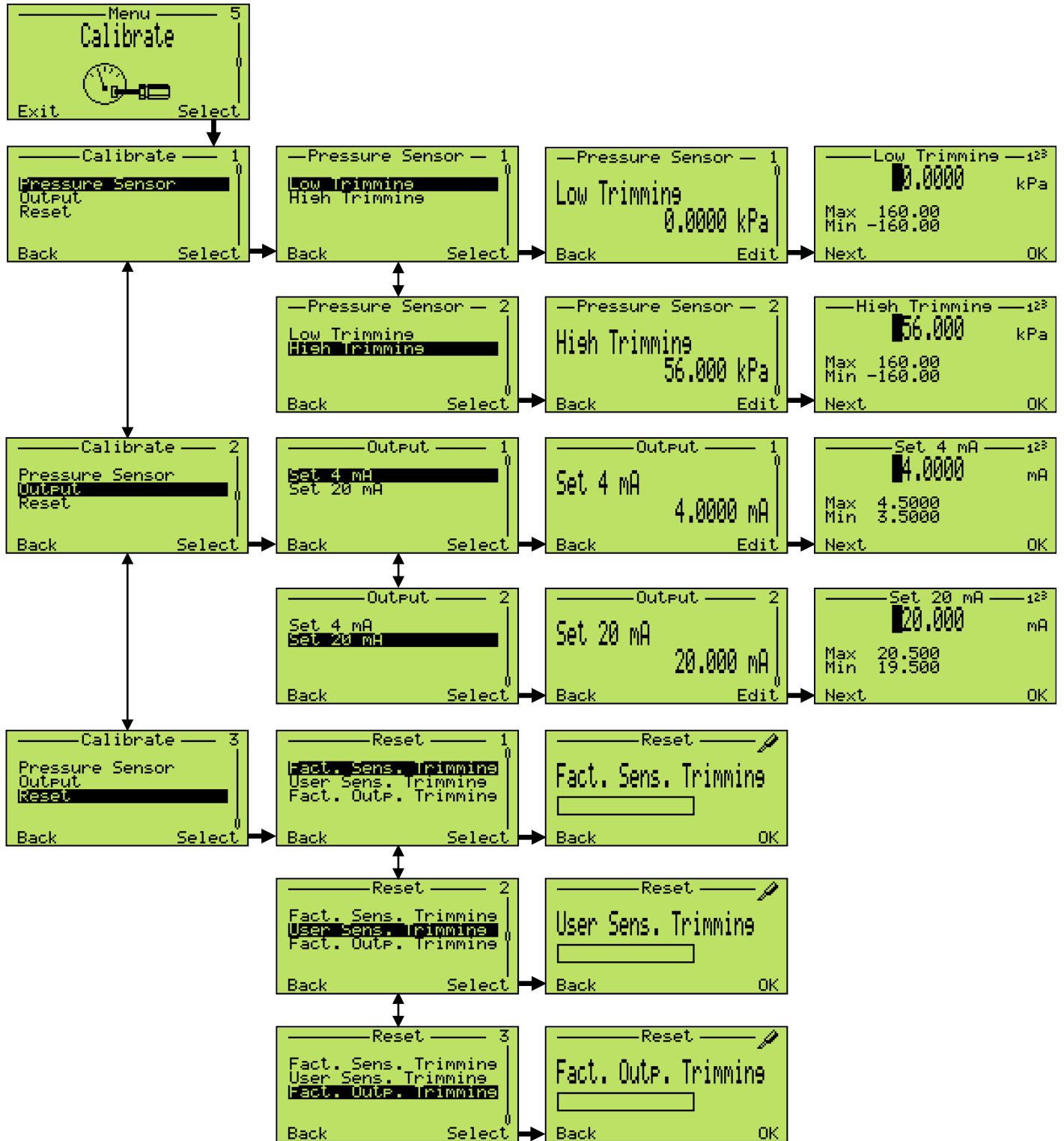

Totalizer

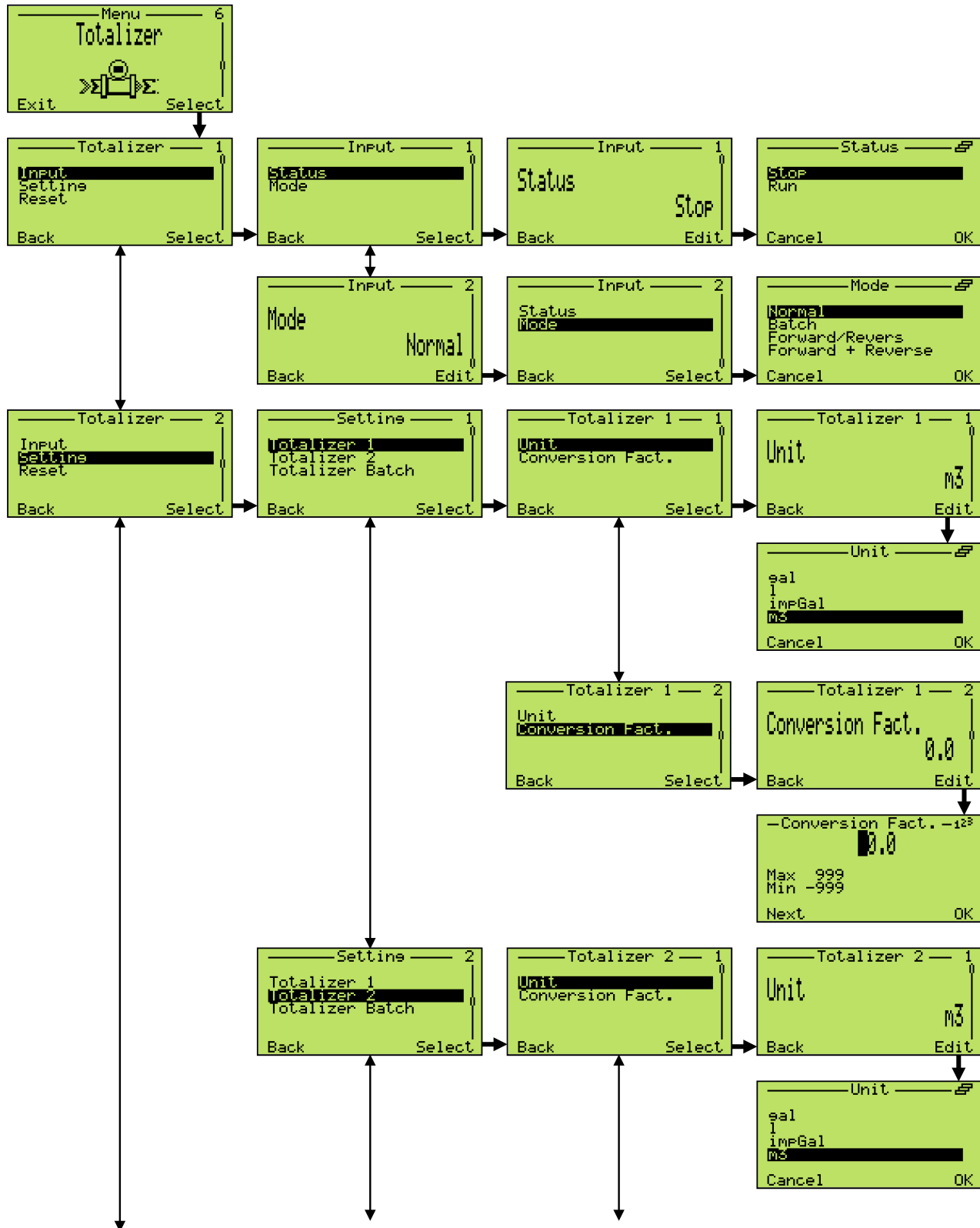

266 Models - HART

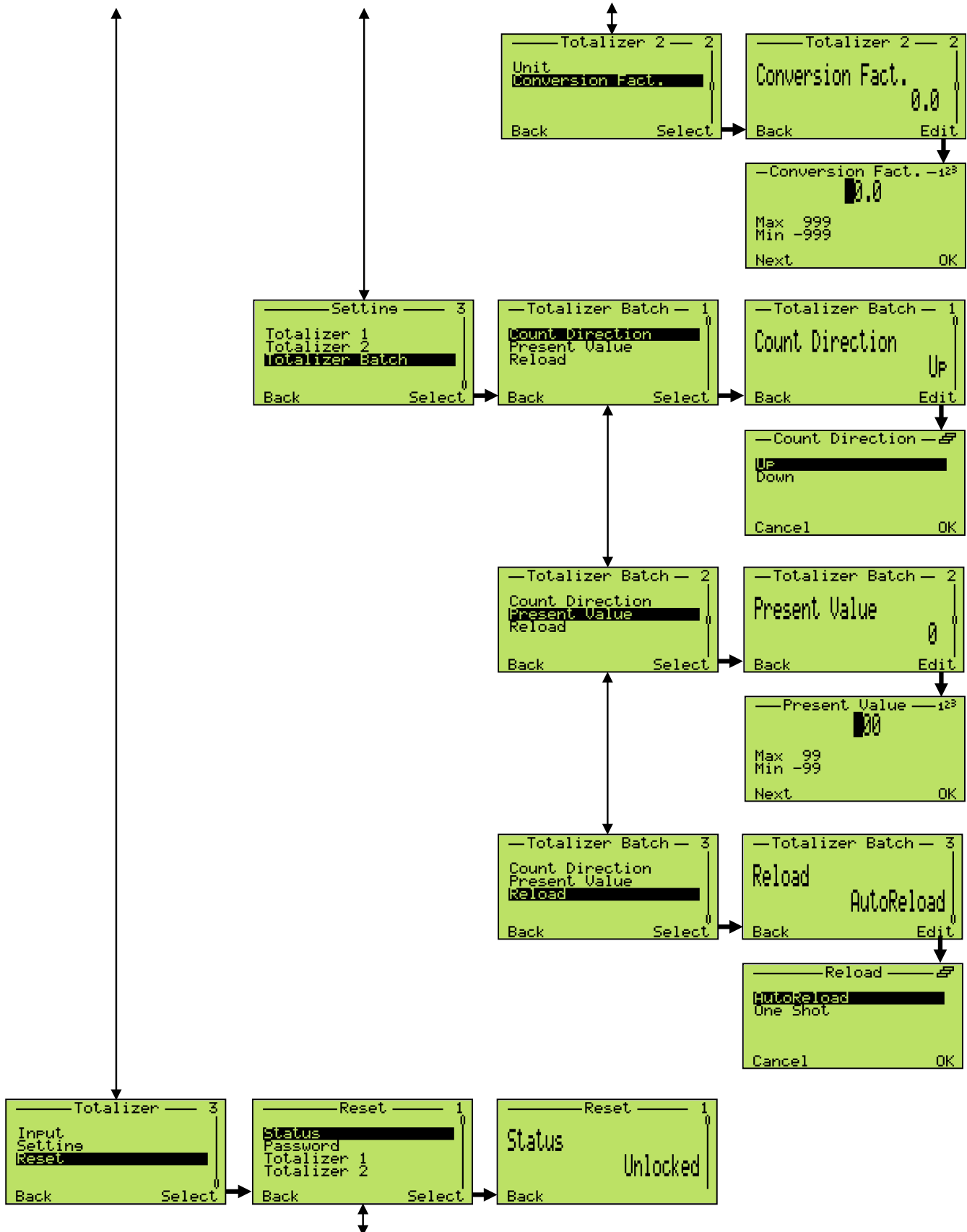

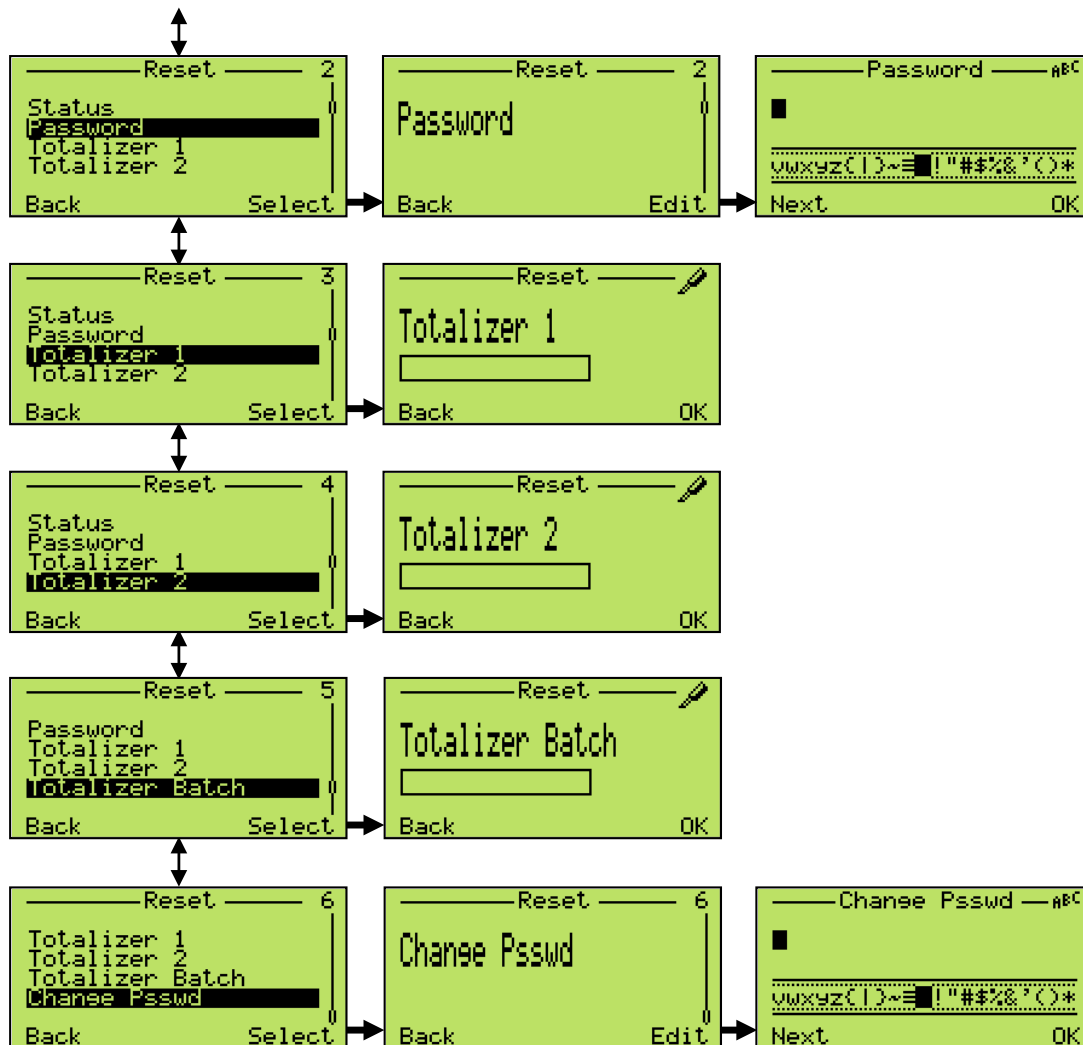

266 Models - HART

Diagnostics

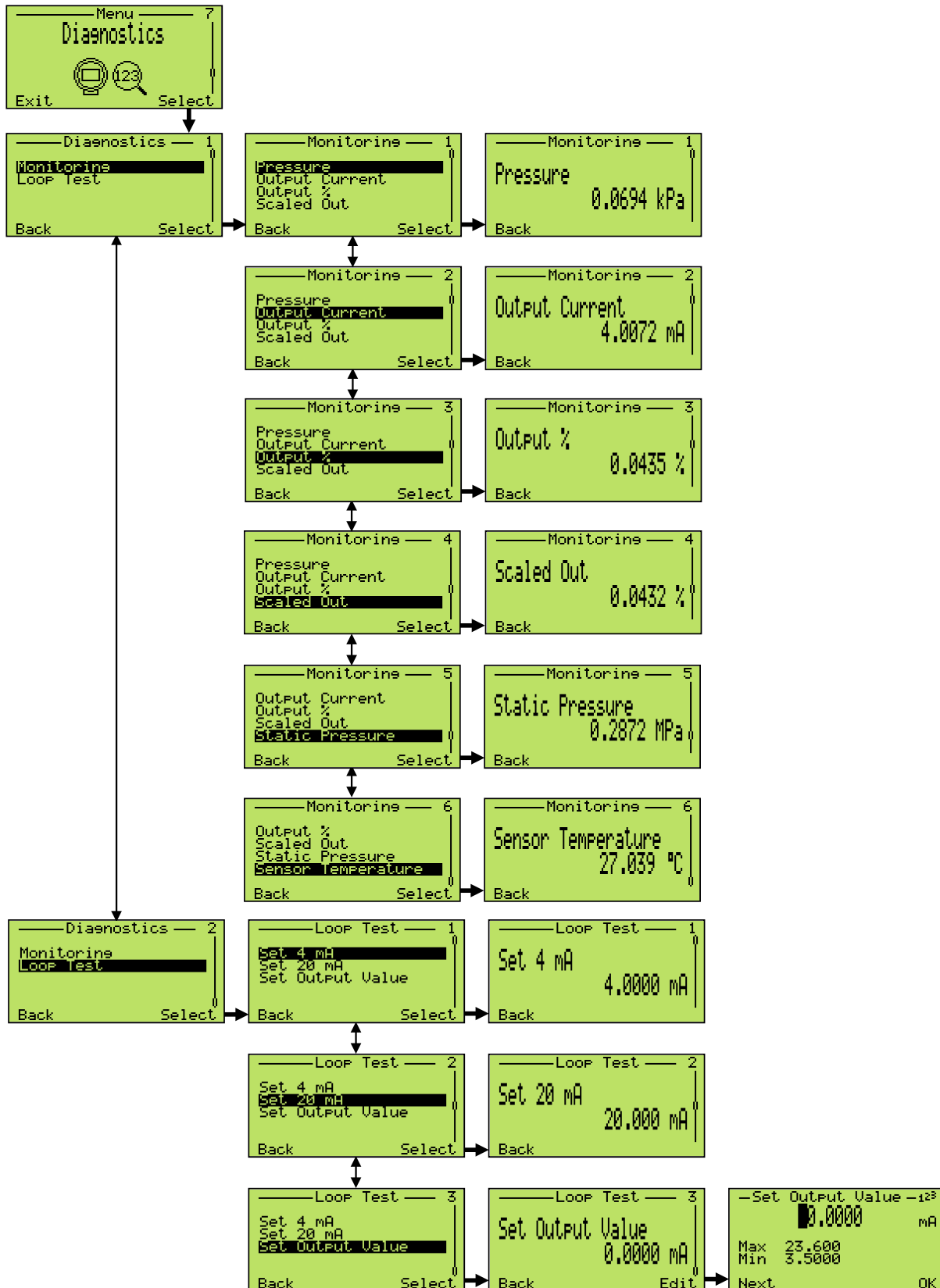

Device Info

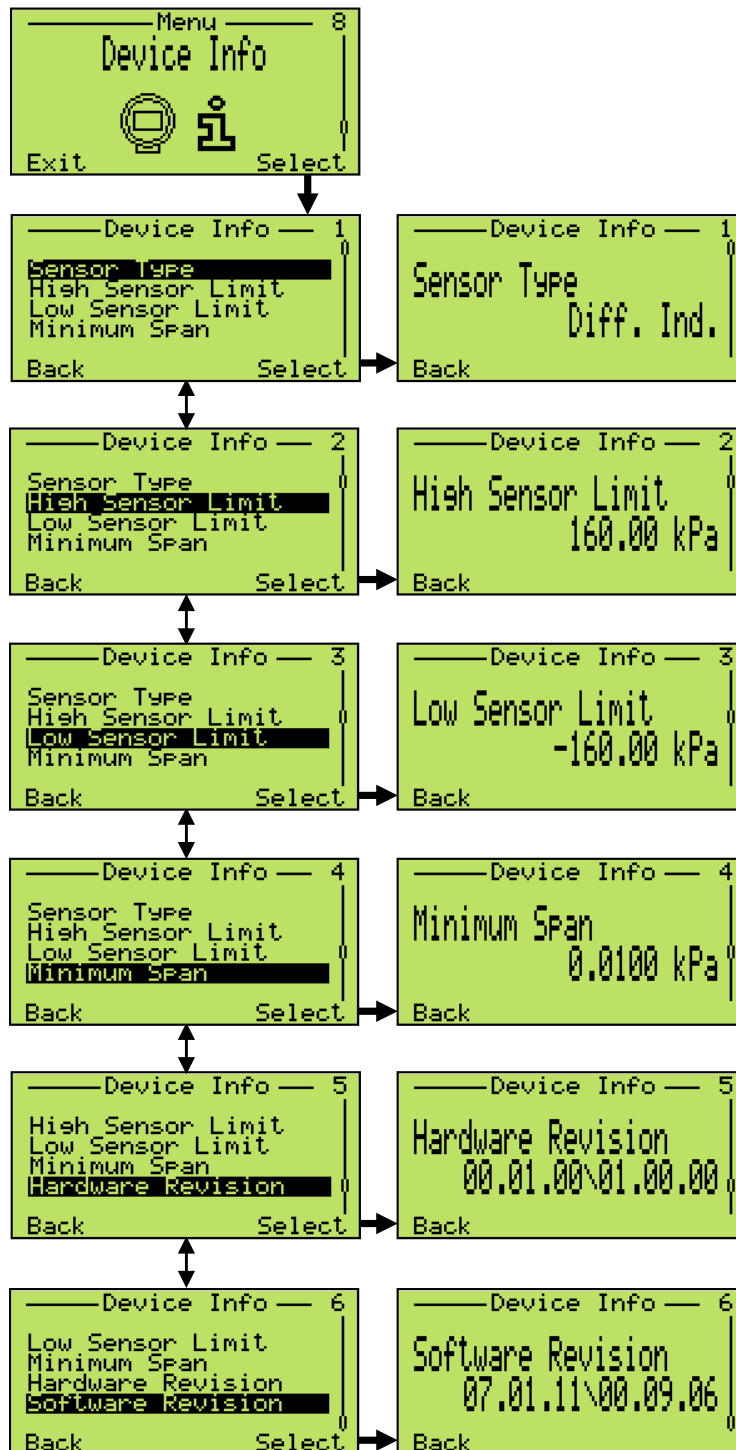

266 Models - HART

Communication

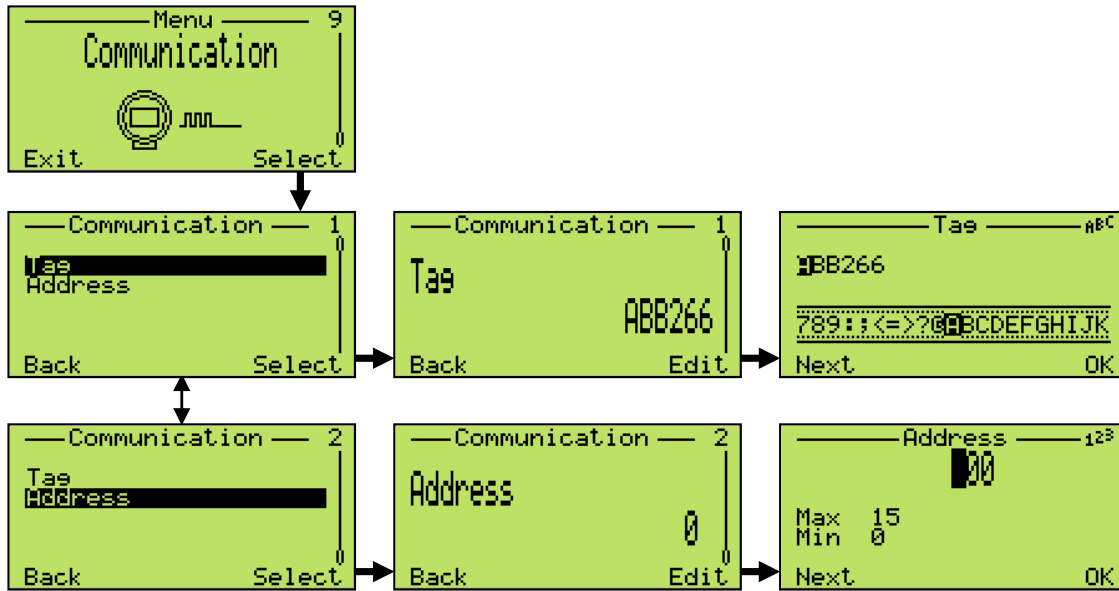

Damping (DAMPING)

Pressure transmitter output signals that are noisy as a result of the process can be smoothed (damped) electrically.

The additional time constant can be set between 0 s and 60 s in increments of 0.0001 s. Damping does not affect the value shown on the digital display as a physical unit. It only affects the parameters derived from this, such as the analog output current, free process variable, input signal for the controller, and so on.

The damping adjustment can be performed in different ways:

- Via the the local HMI:
 - Enter the menu: > Device Setup > Output Scaling > Damping
 - Set the damping to the desired value.
- Via the Asset Vision Basic Software:
 - See Asset Vision Software Operating Instructions
- Via the Hand Held Terminal
 - See relevant operating instruction

Transfer function

The 266 Pressure Transmitter provides a selection of output functions, as follows:

- Linear for differential, gauge and absolute pressure or level measurements
- Sq. Root (x) for flow measurements using restriction type primary element, like orifice plate, integral orifice, Venturi or Dall tube and similar.
- Sq. Root (x3) for open channel flow measurements using rectangular or trapezoidal weir
- Sq. Root (x5) for open channel flow measurements using V-notch (triangular) weir.
- Bidirectional Flow
- Custom linearization table
- Cylindrical lying tank
- Spherical tank

These output functions can be activated using a Configuration Tool (Digital LCD Integral Display, Hand Held Communicator or PC based software as Asset Vision Basic). The transfer function can be applied to the analog signal 4 to 20 mA only or also to the indication (in engineering units).vant operating instruction

Transfer functions description

Linear

Using this function, the relationship between the input (measured value), expressed in % of the calibrated span and the output is linear (i.e.: at 0% input, corresponds 0% output - 4mA, at 100% input corresponds 100% output - 20mA). No further settings are possible here.

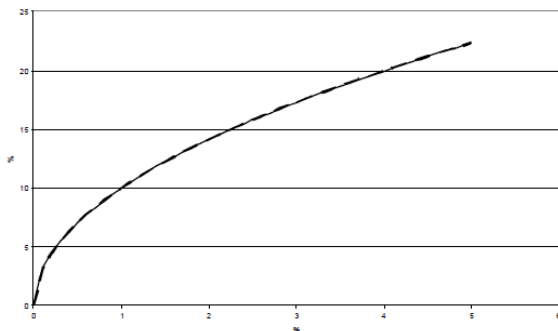

Figure 45: Linear output

Square root

Using the Square Root function, the output (in % of the span) is proportional to the square root of the input signal in percentage of the calibrated span (i.e.: the instrument gives an analog output proportional to the rate of flow).

The possibility to have the full Square Root function is given.

To avoid the extremely high gain error with the input approaching zero, the transmitter output is linear with the input up with a slope of 1 up to 0.5% and then still linear with the appropriated slope to a programmable percentage value between 10 % and 20%. This option is offer in order to ensure a more stable output when the signal is close to zero avoiding errors due to the high gain of the square root.

To neglect the values with the input approaching zero, the transmitter output is zero with the input up to a programmable percentage value between 0 % and 20%. This option is offer in order to ensure a more stable flow measure. This option is possible for all the listed output functions.).vant operating instruction

266 Models - HART

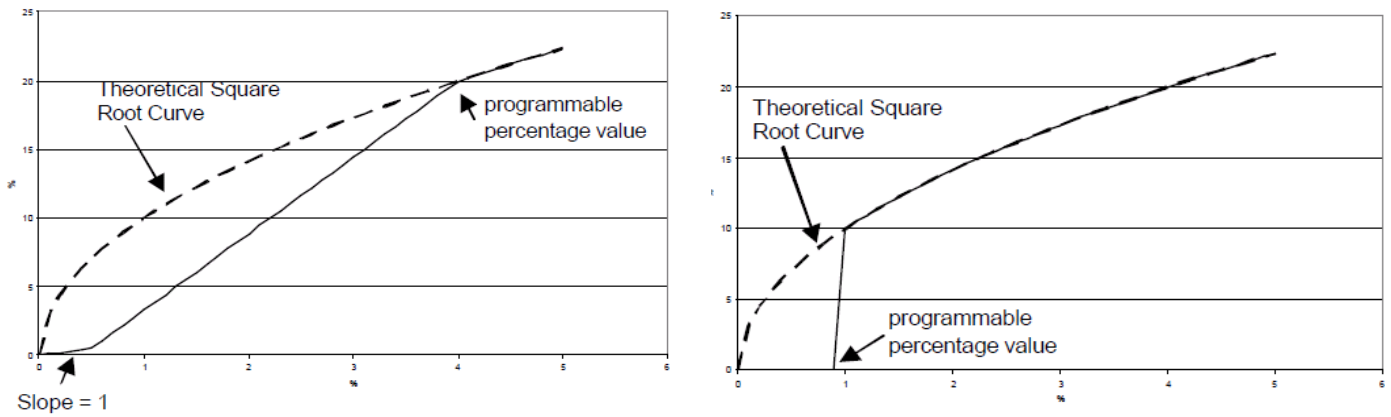

Figure 46: Square-Root transfer functions

Square root to the 3rd power

The x3 Square root Transfer function can be used for open channel (see figures on the right) flow measurement using ISO 1438 rectangular weirs (Hamilton Smith, Kindsvater-Carter, Rehbock formulas) or trapezoidal weirs (Cippoletti formulas) and ISO 1438 Venturi flumes. In these types of devices the relationship between the flow and the developed head h (the differential pressure measured by the transmitter) is proportional to $h^{3/2}$ or square root of h^3 . Other types of Venturi or Parshall flume do not follow this relationship.

Using this function, the output (in % of the span) is proportional to the square root of the third power of the input signal in % of the calibrated span: the instrument gives an output proportional to the rate of flow calculated using the above mentioned formulas.

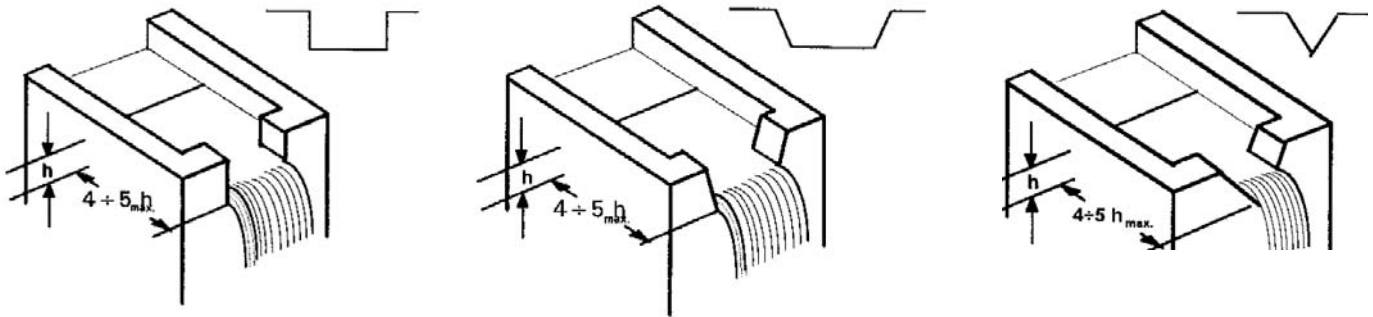

Figure 47: Tanks (respectively rectangular weir, trapezoidal weir and V-notch weir)

Square root to the 5th power

The x5 Square root Transfer function can be used for open channel flow measurement using ISO 1438 V-notch (triangular) weirs (see figure on the right) where the relationship between the flow and the developed head h (the differential pressure measured by the transmitter) is proportional to $h^{5/2}$ or square root of h^5 .

Using this function, the output (in % of the span) is proportional to the square root of the fifth power of the input signal in % of the calibrated span: the instrument (it gives an output proportional to the rate of flow calculated using the Kingsvater-Shen formula).

Custom linearization curve

The custom linearization curve transfer function it is used typically for volumetric level measurement in tanks with an irregular shape. It can be registered to a freely identifiable transfer function with a maximum of 22 base points. The first point is always the zero point, the last is always the final value. Neither of these points can be altered.

A maximum of 20 points can be freely entered in between.

These points have to be defined by extrapolating the tank filling table data and reducing them to 22 points. Once identified the 22 points they will need to be uploaded into the device by either using an HART hand held terminal or a proper configuration software like Asset Vision Basic.

Bidirectional Flow (to be used when the transmitter is connected to a bidirectional flow element)

Main characteristics

The bidirectional function, applied to the transmitter input (x) expressed in percentage of the calibrated span, has the following form:

$$\text{Output} = \frac{1}{2} + \frac{1}{2} \text{sign}(x) \cdot x \cdot \frac{1}{2}$$

where “x” and “Output” should be normalized in the range 0 to 1 for calculation purpose, with the following Output meaning:

- Output = 0 means Analog out 4 mA;
- Output = 1 means Analog out 20 mA.

This function can be used for flow measurement purpose when the flow is in both the directions and the primary elements are designed to perform this type of measure.

As an example, if we have a bidirectional flow measurement application with the following data:

Max reverse flow rate: -100 l/h

Max flow rate: +100 l/h

The differential pressure generated by the flow primary is for the maximum flow rate 2500 mmH₂O, for the max reverse flow rate 2500 mmH₂O.

The transmitter will have to be configured as follows:

Calibrated span: 4mA = LRV = -2500mmH₂O

20mA = URV = +2500mmH₂O

Transfer function: Bidirectional flow

Once configured as above the transmitter will deliver:

flowrate 100 l/h reverse: output= 4 mA

no flowrate: output= 12 mA

Flow rate 100 l/h: output= 20 mA

Cylindric lying tank

This function is used to measure the volumetric level into a cylindrical horizontal tank with flat ends. The transmitter calculates the volume from the measured filling level.

Spherical Tank

This function is used to measure the volumetric level into a spherical tank. The transmitter calculates the volume from the measured filling level.

Configuration with the PC/laptop or handheld terminal

A graphical user interface (DTM) is required for configuration of the transmitter via PC or laptop. For operating instructions, please refer to the software description.

The 266 transmitters can be configured by either one of the following device.

- Hand Held terminals like the ABB 691HT, ABB DHH800-MFC, Emerson Process 375 and 475 provided the 266 EDD has been downloaded and enabled in the terminal.
- ABB Asset Vision Basic, a new free of charge software configurator downloadable at www.abb.com/Instrumentation
- Any DTM based software for HART instruments configuration provided it is compatible with EDD or DTM.

266 Models - HART

You can use a handheld terminal to read out or configure/calibrate the transmitter. If a communication resistor is installed in the connected supply unit, you can clamp the handheld terminal directly along the 4 ... 20 mA line. If no communication resistor is present (min. 250 Ω), you will need to install one in the line. The handheld terminal is connected between the resistor and transmitter, not between the resistor and supply unit.

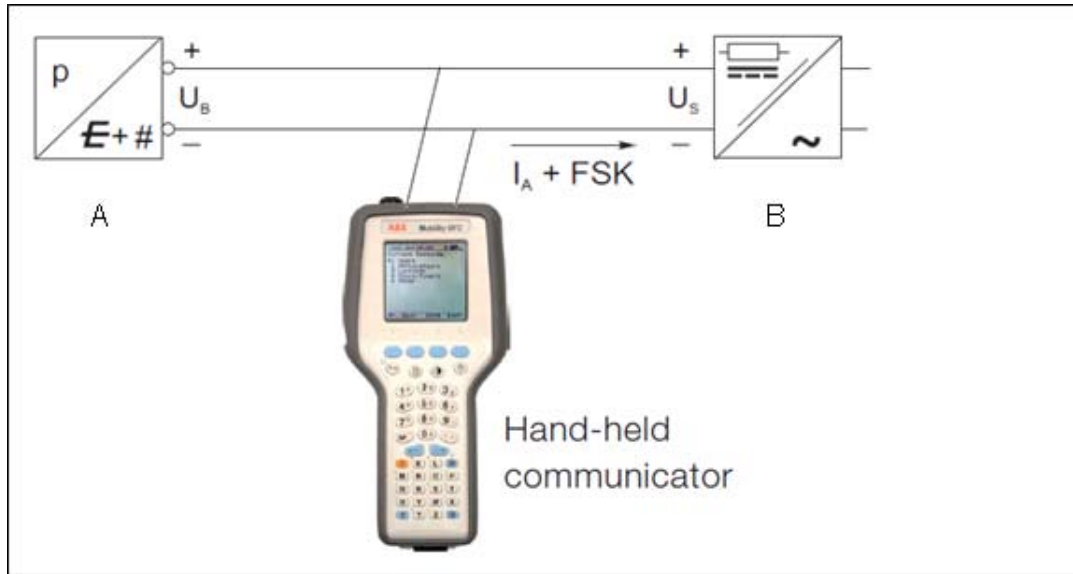

A - Transmitter
 B - Supply unit
 (communication resistor not provided in supply unit)

Figure 48: Communication setup with handheld terminal

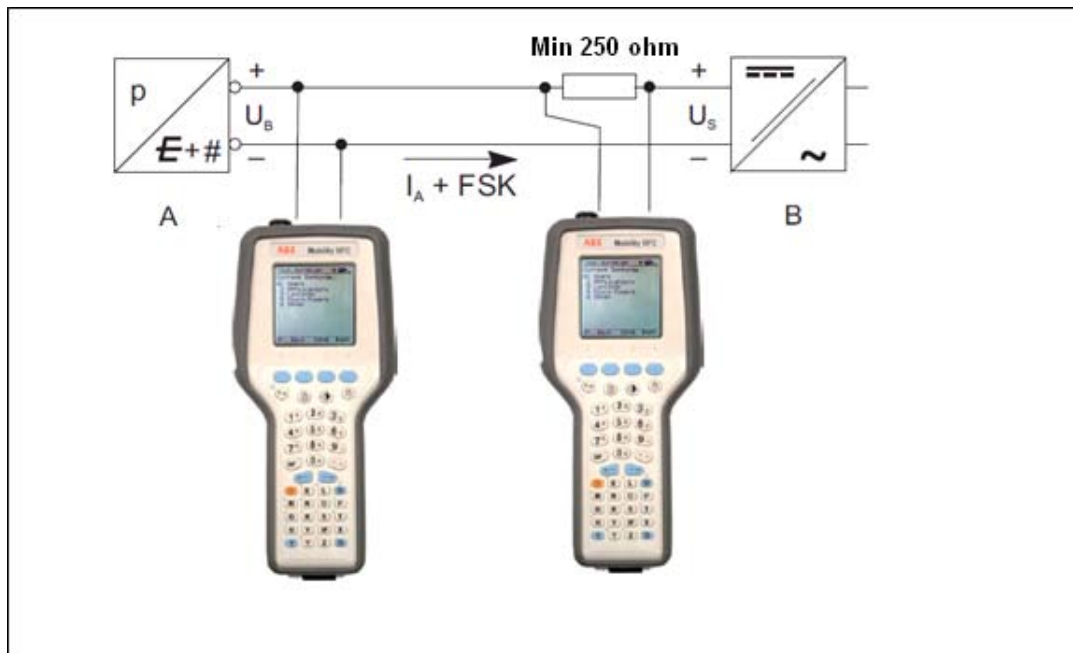

A - Transmitter
 B - Supply unit
 (communication resistor not provided in supply unit)

Figure 49: Connection examples with communication resistor in the connection line

For additional information, refer to the operating instructions included with the handheld terminal.

If the transmitter has been configured in the factory according to customer specifications for the measuring point, all you have to do is mount the transmitter as prescribed (to correct potential zero shifts, refer to the section “Correcting the zero shift”), and switch it on. The measuring point will now be ready for use.

If, however, you wish to make changes to the configuration, a handheld terminal or - preferably - a graphical user interface (DTM) is required. This DTM tool renders the device fully configurable. It supports both the HART protocol and PROFIBUS PA fieldbus protocol, and can be run on a PC or laptop, or as part of an automation system. Where FOUNDATION Fieldbus is concerned, the device description (DD), which can be loaded onto various configuration tools, is required for configuration purposes.

Refer to the installation manual provided with the software for the steps required to install the operating tool. The most important parameters can be set via the path “Parametrize_Differential Pressure Measurement”.

The program offers the option of configuring, polling, and testing the transmitter.

In addition, offline configuration can be performed by means of an internal database.

Each configuration step is subject to a plausibility check. You can call up context-sensitive help at any time by pressing the “F1” key. Immediately after you have received the transmitter or before you change the configuration, we recommend that you save the existing configuration data to a separate data storage medium, via the path “File_Save”.

Configuration with the graphical user interface (DTM)

System requirements

- Operating control program (e.g., ABB Asset Vision Basic version 1.00.17 or higher)
- DTM (Device Type Manager; graphical user interface)
- Operating system (depending on the respective control program)

To operate the Asset Vision Basic please refer to the relevant operating instruction.





Error messages

LCD Display

The LCD HMI in case of transmitter errors or malfunctioning is capable of displaying specific error/fault messages to help the user in identifying the problem and resolve it.

In case of an alarm, a message consisting of an icon and text appears at the bottom of the process display. Use the (1) key to call up the information level. Use the “Diagnostics” menu to call up the error description with a help text.

In the error description, the error number is displayed in the second line (M028.018). Two further lines are used to describe the error. The device status is divided into four groups.

Icon	Description
	Error / Failure
	Functional check (e.g. during simulation)
	Out of Spec (e.g. operating with empty meter pipe)
	Maintenance required

The message text beside this icon in the display provides information about where to look for the error.

There are the following areas: Electronic, Sensor, Configuration, Operating and Process.

266 Models - HART

Error states and alarms

Error list

– Communication Board / Electronic related error messages.

Error message	Tx LCD message	Possible cause	Suggested action	Tx response
F116.023	Electronic Memory Failure	Electronic memory corrupted	The electronic must be replaced	Analog Signal to Alarm
F108.040	Output ReadBack Failure	The output circuit could be broken or not correctly calibrated	A DAC (digital to outpt converter) trimming should be performed and if the error persists the communication board must be replaced	Analog Signal to Alarm
M030.020	Electronic Interface Error	Data exchange between the sensor and the electronic is incorrect	Power off and on the transmitter and check if the error persists. If yes replace the communication board as soon as possible.	no effect
M026.024	NV Electronic Memory Burn Error	Writings to the electronic non-Volatile Memory has not been successful	The communication board should be replaced as soon as possible	no effect
F106.035	Unreliable Output Current	The D to A converter is not properly Calibrated/Trimmed	Perform an Output Trimming and if the error persists the communication board must be replaced	Analog Signal to Alarm
F106.035	Unreliable Output Current	The Device is not properly configured	Check the device configuration	Analog Signal to Alarm

– Sensor related error messages

Error message	Tx LCD message	Possible cause	Suggested action	Tx response
F120.016	Sensor Invalid	The sensor signal is not being updated correctly as a result of an electronics failure, sensor error or a poorly connected sensor cable.	Check cable connection, check sensor and if problem persists, the sensor must be replaced.	Analog Signal to Alarm
F120.016	Sensor Invalid	The sensor model/version is no longer compatible with the connected electronic version	The sensor must be replaced	Analog Signal to Alarm
F118.017	Sensor Memory Fail	Sensor memory corrupted	The sensor must be replaced	Analog Signal to Alarm
F114.000	P-dP Sensor Fail	Mechanical damage to the sensor. Loss of fill fluid from the cell, ruptured diaphragm, broken sensor.	The sensor must be replaced	Analog Signal to Alarm
F112.001	Static Pressure Sensor Fail	The circuitry for the sampling of the static pressure has failed.	The sensor must be replaced	Analog Signal to Alarm
F110.002	Sensor Temperature Fail	The circuitry for the sampling of the temperature has failed.	The sensor must be replaced	Analog Signal to Alarm
M028.018	NV Sensor Memory Burn Error	Writings to the sensor non-Volatile Memory was not successful	The sensor should be replaced as soon as possible.	no effect

– Configuration related error messages.

Error message	Tx LCD message	Possible cause	Suggested action	Tx response
C088.030	Input Simulation Active	The P-dP Value produced in output is derived by the value simulated in input	Use a HART configurator (DTM - Hand held) to place device back in to normal operating mode (Remove the input simulation)	no effect
C088.030	Input Simulation Active	The Static Pressure Value produced in output is derived by the value simulated in input	Use a HART configurator (DTM - Hand held) to place device back in to normal operating mode (Remove the input simulation)	no effect
C088.030	Input Simulation Active	The Sensor Temperature Value produced in output is derived by the value simulated in input	Use a HART configurator (DTM - Hand held) to place device back in to normal operating mode (Remove the input simulation)	no effect
M014.037	Configuration Error	Refer to the Instruction manual to understand the possible cause of this error	Use a HART configurator (DTM - Hand held) to correct the configuration	no effect
M020.042	Replace Info	The Electronics or the Sensor have been changed but the replacement operation has not been executed	The replacement operation must be executed: Move the SW 1 of the electronics in position 1 = Enable replace mode -Select the SW 2 the element that has been changed between new Sensor or new electronics -Power Cycle the device -Move the SW 1 of the electronics in position 0	no effect
M020.042	Replace Info	The Electronics or the Sensor have been changed and a replacement operation for a new sensor has to be executed.	The replacement operation must be executed: Only the data of the electronics can be copied into the sensor- Move the SW 1 to Enable replace mode (1)-Select with the SW 2 to New Sensor (1)-Power Cycle the device- Move the SW 1 to Disable replace mode (0)	no effect
M020.042	Replace Info	The Electronics or the Sensor have been changed, The replacement has been enabled but with a wrong direction (SW 2 = 0).	Change the replacement direction (if possible)-The SW 1 is already set to Enable replace mode (1)-Select with the SW 2 to New Sensor (1)-Power Cycle the device-Move the SW 1 to Disable replace mode (0)	no effect

– Operation related error messages

Error message	Tx LCD message	Possible cause	Suggested action	Tx response
M024.036	Power Supply Warning	the Device Power Supply is close to the lowest acceptable limit	Check the Voltage at the terminal block and if it is not within the valid range check the external power supply	no effect
M024.036	Power Supply Warning	the Device Power Supply is close to the highest acceptable limit	Check the Voltage at the terminal block and if it is not within the valid range check the external power supply	no effect
M022.041	Electronic Temperature Out of Limits	The Electronics temperature is out of its lower acceptable limit . The circuitry for the sampling of the Electronics Temperature has failed.	The Electronics should be replaced as soon as possible.	no effect
M022.041	Electronic Temperature Out of Limits	The Electronics temperature is out of its Higher acceptable limit. The circuitry for the sampling of the Electronics Temperature has failed.	The Electronics should be replaced as soon as possible.	no effect

266 Models - HART

– Process related error messages.

Error message	Tx LCD message	Possible cause	Suggested action	Tx response
F104.032	Pressure Overrange	This effect could be produced by other equipment on the process, (valves....). Exceeding the pressure range can cause reduced accuracy or mechanical damage to the diaphragm material and may require calibration/replacement.	The compatibility of pressure transmitter model and process conditions has to be checked. A different transmitter type could be required	no effect
F102.004	P-dP Out Of Limits	The measurement range has not been correctly calculated OR an incorrect transducer model has been selected.	The compatibility of pressure transmitter model and process conditions has to be checked. Probably a different transmitter type is required.	no effect
F100.005	Static Pressure Out of Limits	The static pressure of the process exceeds the limit of the sensor. Exceeding the Static Pressure can reduce accuracy, mechanically damage the diaphragm and may require calibration/replacement. An incorrect transducer model could have been selected.	The compatibility of pressure transmitter model and process conditions has to be checked. Probably a different transmitter type is required.	no effect
S054.006	Sensor Temperature Out of Limits	The temperature of the process environment affects the pressure transmitter; Excess temperature can reduce accuracy, degrade device components and may require calibration/ replacement.	The compatibility of pressure transmitter model and process conditions has to be checked. A different installation type could be required e.g. use of remote seals.	no effect
S052.031	Max Working Pressure Exceeded	The static pressure of the process exceeds the max working Pressure supported by the transmitter. Exceeding the Max Working Pressure can mechanically damage the process connections (flanges, pipes....) and/or be dangerous	The compatibility of pressure transmitter model and process conditions has to be checked.	no effect
F098.034	Analog Output Saturated	The analog output for the Primary Variable is beyond its Low scaling limit and no longer represents the true applied process. The Analog Output (4-20 mA) is saturated to the configured Saturation Limit Low.	Adjust the Saturation Limit or the working range if possible.	no effect
F098.034	Analog Output Saturated	The analog output for the Primary Variable is beyond its High scaling limit and no longer represents the true applied process. The Analog Output (4-20 mA) is saturated to the configured Saturation Limit High.	Adjust the Saturation Limit or the working range if possible.	no effect
M018.038	PILD Output	One (HIGH or LOW) or both connections between the pressure sensor and the process is blocked either by plugging or closed valves.	Check valves and impulse line. Clean impulse line if necessary and initiate PILD training	no effect
M016.039	PILD-Changed Operating Conditions	Process conditions have changed to an extent that new settings for the PILD algorithm are needed.	A new Training is necessary for this new process condition.	no effect

Maintenance

If transmitters are used as intended under normal operating conditions, no maintenance is required. It is sufficient to check the output signal at regular intervals (in accordance with the operating conditions), as described in the instructions in the section “Operation resp. Configuration of the transmitter”. If deposits are expected to accumulate, the measuring equipment should be cleaned on a regular basis, in accordance with the operating conditions. Cleaning should ideally be carried out in a workshop. Repair and maintenance activities may only be performed by authorized customer service personnel. When replacing or repairing individual components, original spare parts must be used.



Attention – Potential damage to parts

The electronic components of the printed circuit board can be damaged by static electricity (observe ESD guidelines). Make sure that the static electricity in your body is discharged when touching electronic components.

If a remote seal is mounted on the measuring equipment, it must not be removed (please refer to the dedicated document).



Warning – <Bodily injury>

Explosion-proof transmitters must be either repaired by the manufacturer or approved by a certified expert following repair work. Observe the relevant safety precautions before, during and after repair work. Only disassemble the transmitter to the extent necessary for cleaning, inspection, repairs, and replacement of damaged components.

Returns and removal

Defective transmitters sent to the repairs department must, wherever possible, be accompanied by your own description of the fault and its underlying cause.



Warning – General risks

Before removing or disassembling the device, check for hazardous process conditions such as pressure on the device, high temperatures, aggressive or toxic media, and so on. Read the instructions in the sections “Safety” and “Electrical connection”, and perform the steps outlined there in reverse order.

Pressure transmitter sensor

Essentially maintenance is not required for the transmitter sensor. Anyway the following items should be checked periodically:

- Check the integrity of the pressure boundary (no cracks should be visible on the process connection or on the process flanges.
- Check that there is no leakage from the sensor/flange interface or from the vent/drain valves.
- The process flanges bolts (for 266DS/MS/PS/VS/RS models) should not show excessive rust.

In case one of the check points above fails, please replace the damaged part with an original spare part.

Please contact your local ABB office for spare parts support information or refer to the spare part list.

The use of non original spare parts makes the warranty void.

In case you want ABB to perform the repair, please send back the transmitter to your local ABB office complete with the return form that you find in this manual appendix and include it with the device.

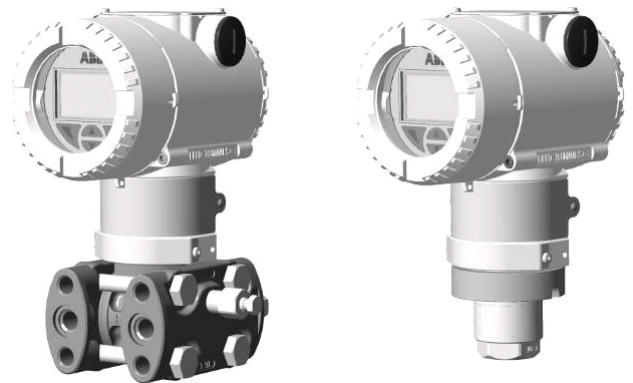

Figure 50: DP and P style pressure transmitter construction

266 Models - HART

Removing/Installing the process flanges

- Slacken the process flange screws by working on each in a crosswise manner (hexagon head, SW 17 mm (0.67 inch) for 266DS/266PS/266VS or SW 13 mm (0.51 inch) for 266MS/266RS).
- Carefully remove the process flange, making sure that the isolating diaphragms are not damaged in the process.
- Use a soft brush and a suitable solvent to clean the isolating diaphragms and - if necessary - the process flange.
- Insert the new process flange O-rings in the process flange.
- Attach the process flange to the measuring cell.

The surfaces of both process flanges must be at the same level and at a right angle to the electronics housing (with the exception of vertical process flanges).

- Check that the process flange screw thread can move freely: Manually turn the nut until it reaches the screw head. If this is not possible, use new screws and nuts.
- Lubricate the screw thread and seats of the screw connection.
- While performing the preliminary and final tightening of the bolts, please act in a crosswise manner.



Attention – Potential damage to parts

Do not use sharp or pointed tools.



Attention – Potential damage to parts

Do not damage the insulating diaphragms.



Important

In the case of oil and grease-free designs, clean the measuring chambers again if necessary once the process flange has been installed.

- Respect the below table indications for reinstalling the process flanges.

Transmitter model and range			Procedure
266DSH / PSH / VSH	Viton Gaskets	All bolting	Use a torque wrench to tighten the bolts to a torque of 25 Nm.
	PTFE Gaskets	Carbon Steel NACE and Stainless Steel	Use a torque wrench to tighten the process flange nuts to a torque of 40 Nm, let the flange stabilize for an hour, unscrew the nuts and tighten again to 25 Nm.
		Stainless Steel NACE	Use a torque wrench to tighten the process flange nuts to a torque of 25 Nm, let the flange stabilize for an hour and perform the final tightening to 25 Nm.
266DSH.x.H (High static option)	Viton Gaskets	All bolting	Use a torque wrench to tighten the bolts to a torque of 31 Nm.
	PTFE Gaskets	All bolting	Use a torque wrench to tighten the process flange nuts to a torque of 40 Nm, let the flange stabilize for an hour, unscrew the nuts and tighten again to 31 Nm.
266DSH range A (1KPa)	All gaskets	All bolting	Use a torque wrench to tighten the process flange screws/nuts to a torque of 14 Nm. Please be aware that in case of bottom work disassembly and reassembly the original performances can not be guarantee anymore.
266DSH / 266PSH with Kynar inserts	All gaskets	All bolting	Use a torque wrench to tighten the process flange screws/nuts to a torque of 15 Nm
266MSx / 266RSx	All gaskets	All bolting	First, use a torque wrench to tighten the process flange screws/nuts to a joining torque of - MJ = 2 Nm (0.2 kpm), working in a crosswise manner. - Then tighten them with a torque MJ = 10 Nm (1.0 kpm), working in a crosswise manner - Then tighten them fully by turning each nut or screw again (in a crosswise manner) by the tightening angle A = 180°, working in two stages of 90° each. Some transmitter versions are using screws with size M10. If this screws are used the tightening angle A = 270°, working in three stages of 90° each.

Pressure transducer replacement

If the pressure transducer needs to be replaced proceed as follows:

- Insulate the transmitter from the process by acting on the manifolds or on the insulation valves
- Open the vent valves to allow sensor depressurization
- Disconnect the power supply and disconnect the wiring to the transmitter
- Disconnect the transmitter from its bracket by loosening on the four fixing bolts (a).

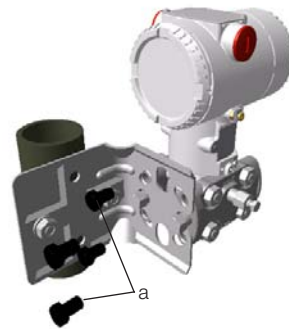

Figure 51: Bracket fixing bolts

- You should now open the communication board housing compartment cover as shown by the figure here on the right.



Figure 52: Display removing

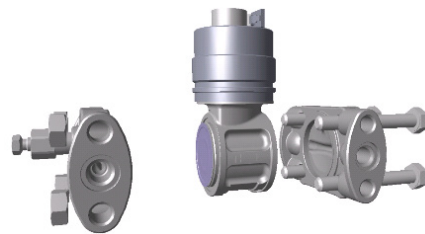

Figure 56: Flange disassembly

- The communication board is connected to the sensor via a flat cable and a connector. Remove the communication board by releasing the two fixing screws (b) and gently disconnect the connector from the communication board.

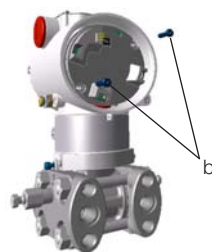

Figure 53: Communication board removing

- The transmitter housing needs now to be disconnected from the pressure transducer.

To accomplish such operation, it is necessary to release the tang screw (c) until you will be able to rotate easily the housing.



Figure 54: Tang screw removing from the housing

- Continue to rotate the electronic housing counterclockwise until its complete removal, as shown by the figure here on the right.



Figure 55: Communication flat between the sensor and the electronic module

- Unscrew the fixing bolts from the transducer and remove the process flanges.

- The orings placed between the diaphragm and the flange (Viton or PTFE) must be replaced after every disassembly.
- Reassemble the flanges following the steps above in reverse order.

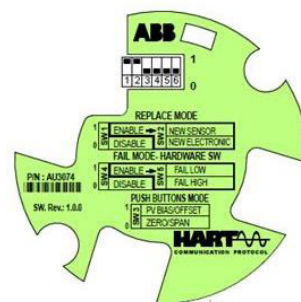

Figure 57: HART communication board

- The 266 can reconfigure itself with the previous configured parameters thanks to the auto-configuration functionality.
- Before powering on the transmitter raise dip-switches 1 and 2 in up position. Connect the transmitter to power supply, wait ten seconds and lower dip-switched 1 and 2 .
- A PV zero bias operation is recommended to align the zero to the installation. This operation should be accomplished after the transmitter has been installed back to its bracket and connected to the manifold. See “Correcting the lower range value / zero shift”.

266 Models - HART

Hazardous Area considerations

Ex Safety aspects and IP Protection (Europe)

According to ATEX Directive (European Directive 94/9/EC of 23 March 1994) and relative European Standards which can assure compliance with Essential Safety Requirements, i.e., EN 60079-0 (General requirements) EN 60079-1 (Flameproof enclosures "d") EN 60079-11 (Equipment protection by intrinsic safety "i") EN 60079-26 (Equipment with equipment protection level -EPL- Ga) EN 61241-0 (General requirements) EN 61241-1 (Protection by enclosures "tD") EN 61241-11 (Protection by intrinsic safety "iD") the pressure transmitters of the 2600T SERIES have been certified for the following group, categories, media of dangerous atmosphere, temperature classes, types of protection.

Examples of application are also shown below by simple sketches. & Sohn GmbH & Co. KG, Münster, Germany).

a) Certificate ATEX II 1 G Ex ia IIC T4/T5/T6 and II 1 D Ex iaD 20 T85°C

FM Approvals certificate number FM09ATEX0024X (Lenno products) and FM09ATEX0069X (Minden products)

The meaning of ATEX code is as follows:

II : Group for surface areas (not mines)

1 : Category

G : Gas (dangerous media)

D: Dust (dangerous media)

T85°C: Maximum surface temperature of the transmitter enclosure with a Ta (ambient temperature)

+40°C for Dust (not Gas) with a dust layer up to 50 mm depth.



Important

The number close to the CE marking of the transmitter safety label identifies the Notified Body which has responsibility for the surveillance of the production.

The other marking refers to the protection type used according to relevant EN standards:

Ex ia: Intrinsic safety, protection level "a"

IIC: Gas group

T4: Temperature class of the transmitter (which corresponds to 135°C max) with a Ta from -50°C to +85°C

T5: Temperature class of the transmitter (which corresponds to 100°C max) with a Ta from -50°C to +40°C

T6: Temperature class of the transmitter (which corresponds to 85°C max) with a Ta from -50°C to +40°C

About the applications, this transmitter can be used in "Zone 0" (Gas) and "Zone 20" (Dust) classified areas (continuous hazard) as it is shown on the following sketch:

Application for pressure transmitter Ex ia categories 1G and 1D

Application with Gas

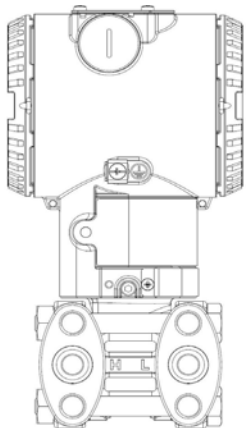

Zone 0

266 Tx Category 1G Ex ia

Note: the transmitter must be connected to a supply (associated apparatus) certified [Ex ia]

Application with Dust

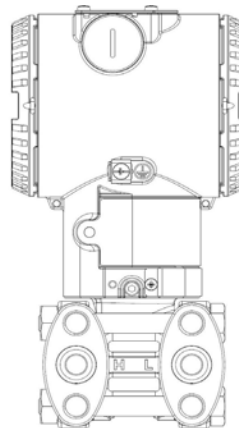

Zone 20

266 Tx Category 1D IP6x (Ex ia)

Note: the protection is mainly assured by the "IP" degree associated to the low power from supply. This can either be [ia] or [ib] certified [Ex ia]

b) Certificate ATEX II 1/2 G Ex ia IIC T4/T5/T6 and II 1/2 D Ex iaD 21 T85°C
 FM Approvals certificate number FM09ATEX0024X (Lenno products) and FM09ATEX0069X (Minden products)

i Important

This ATEX Category depends on the application (see below) and also on the intrinsic safety level of the transmitter supply (associated apparatus) which can sometimes suitably be [ib] instead of [ia]. As it is well known, the level of an intrinsic safety system is determined by the lowest level of the various apparatus used, i.e., in the case of [ib] supply, the system takes over this level of protection.

The meaning of ATEX code is as follows:

II: Group for surface areas (not mines)

1/2: Category - It means that only a part of the transmitter complies with category 1 and a second part complies with category 2 (see next application sketch).

G: Gas (dangerous media)

D: Dust (dangerous media)

T85°C: Maximum surface temperature of the transmitter enclosure with a Ta from -50°C to +40°C for Dust (not Gas) with a dust layer up to 50 mm depth.

T85°C: As before for Dust for a Ta +85°C

(Note: the number close to the CE marking of the transmitter safety label identifies the Notified Body which has responsibility for the surveillance of the production)

The other marking refers to the protection type used according to relevant EN standards:

Ex ia: Intrinsic safety, protection level "a"

IIC: Gas group

T4: Temperature class of the transmitter (which corresponds to 135°C max) with a Ta from -50°C to +85°C

T5: Temperature class of the transmitter (which corresponds to 100°C max) with a Ta from -50°C to +40°C

T6: Temperature class of the transmitter (which corresponds to 85°C max) with a Ta from -50°C to +40°C

About the applications, this transmitter can be used in Zone "0" (Gas) classified areas (continuous hazard) with its "process part" only, whereas the remaining part of the transmitter, i.e. its enclosure, can be used in Zone 1 (Gas), only (see sketch below).

Reason of this is the process part of the transmitter (normally called primary transducer) that provides inside separation elements to seal off the electrical sensor from the continuously hazardous process, according to the EN 60079-26 and EN 60079-1. About Dust application, the transmitter is suitable for "Zone 21" according to the EN 61241-0 and EN 61241-11 as it is shown on the relevant part of the sketch:

Application for pressure transmitter Ex ia categories 1/2G and 1/2D

Application with Gas

Application with Dust

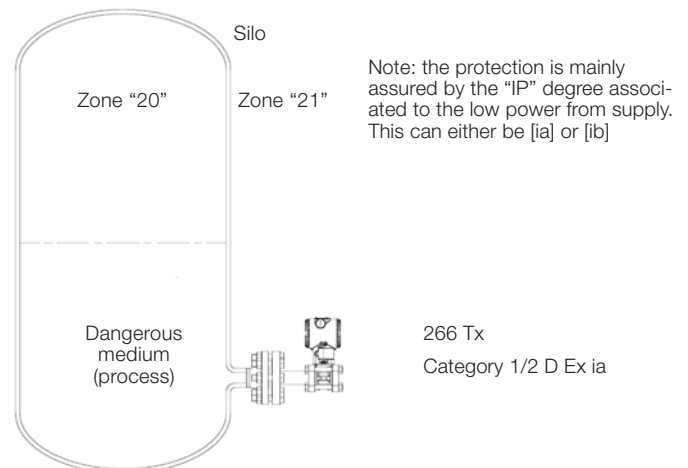
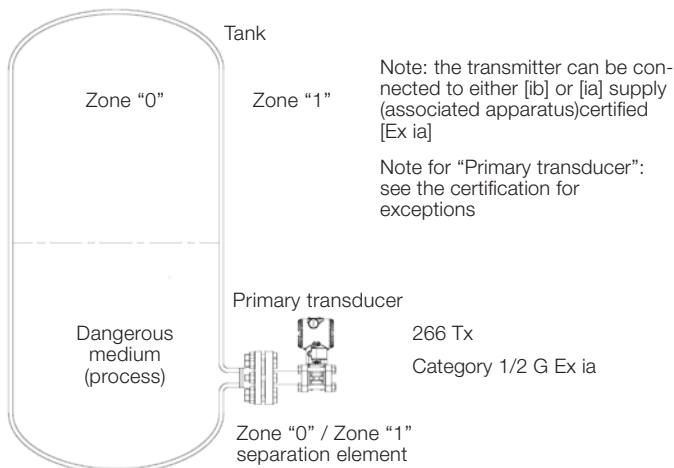

266 Models - HART

c) Certificate ATEX II 1/2 G Ex d IIC T6

ATEX II 1/2 D Ex tD A21 IP67 T85°C (-50°C ≤ Ta ≤ +75°C)

FM Approvals Certificate number FM09ATEX0023X (Lenno products) and FM09ATEX0068X (Minden products)

The meaning of ATEX code is as follows:

II: Group for surface areas (not mines)

1/2: Category - It means that only a part of the transmitter complies with category 1 and a second part complies with category 2 (see next application sketch).

G: Gas (dangerous media)

D: Dust (dangerous media)

T85°C: Maximum surface temperature of the transmitter enclosure with a Ta (ambient temperature) +75°C for Dust (not Gas) with a dust layer up to 50 mm depth.

(Note: the number close to the CE marking of the transmitter safety label identifies the Notified Body which has responsibility for the Surveillance of the production)

The other marking refers to the protection type used according to relevant EN Standards:

Ex d: Explosion proof

IIC: Gas group

T6: Temperature class of the transmitter (which corresponds to 85°C max) with a Ta from -50°C to +75°C.

About the applications, this transmitter can be used in Zone "0" (Gas) classified areas (continuous hazard) with its "process part" only, whereas the remaining part of the transmitter, i.e. its enclosure, can be used in Zone 1 (Gas), only (see sketch below).

Reason of this is the process part of the transmitter (normally called primary transducer) that provides inside separation elements to seal off the electrical sensor from the continuously hazardous process, according to the EN 60079-26 and EN 60079-1.

About Dust application, the transmitter is suitable for "Zone 21" according to the EN 61241-1 as it is shown on the relevant part of the sketch:

Application for pressure transmitter Ex d categories 1/2G and 1/2D

Application with Gas

Application with Dust

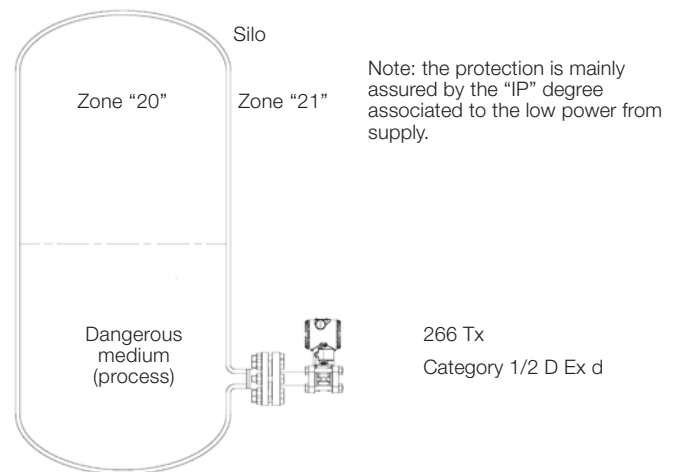
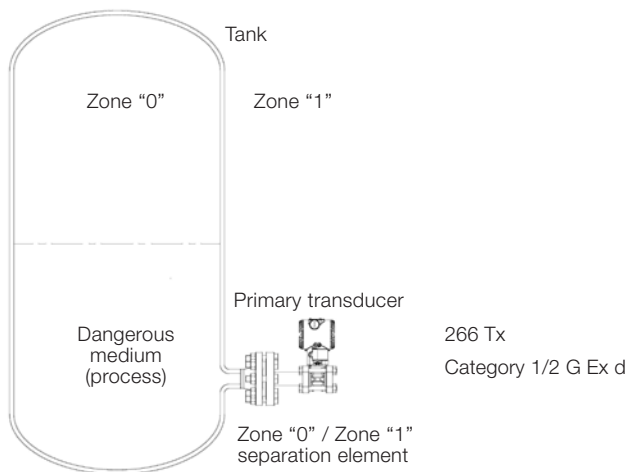

IP code

About the degree of protection provided by the enclosure of the pressure transmitter, the 2600T SERIES has been certified IP67 according to EN 60529 standard. The first characteristic numeral indicates the protection of the inside electronics against ingress of solid foreign objects including dusts.

The assigned "6" means an enclosure dust-tight (no ingress of dust).

The second characteristic numeral indicates the protection of the inside electronics against ingress of water. The assigned "7" means an enclosure water-protected against a temporary immersion in water under standardized conditions of pressure and time.

According to ATEX Directive (European Directive 94/9/EC of 23 March 1994) and relative Standards which can assure compliance with Essential Safety Requirements, i.e., EN 60079-0 (General requirements) EN 60079-15 (Specification for electrical apparatus with type of protection “n”) EN 61241-0 (General requirements), the pressure transmitters of the 2600T SERIES have been certified for the following group, categories, media of dangerous atmosphere, temperature classes, types of protection. Examples of application are also shown below by simple sketches.

d) Certificate ATEX II 3 G Ex nL IIC T4/T5/T6 (for T4 = $-50^{\circ}\text{C} \leq T_a \leq +85^{\circ}\text{C}$), (for T5 and T6 = $-50^{\circ}\text{C} \leq T_a \leq +40^{\circ}\text{C}$) and II 3D Ex tD A22 IP67 T85°C. FM Approvals Certificate number FM09ATEX0025X (Lenno products) and FM09ATEX0070X (Minden products)

i Important
It is the technical support for the ABB Declaration of Conformity

i Important
When installed this transmitter must be supplied by a voltage limiting device which will prevent the rated voltage of 42 V d.c. being exceeded.

The meaning of ATEX code is as follows:

II : Group for surface areas (not mines)

3 : Category

G : Gas (dangerous media)

D : Dust (dangerous media)

+40°C for Dust (not Gas) with a dust layer up to 50 mm depth.

T85°C: As before for Dust for a $T_a +40^{\circ}\text{C}$

The other marking refers to the protection type used according to the standards:

Ex nL: Type of protection “n” with “energy limitation” technique

IIC: Gas group

T4: Temperature class of the transmitter (which corresponds to 135°C max) with a T_a from -50°C to $+85^{\circ}\text{C}$

T5: Temperature class of the transmitter (which corresponds to 100°C max) with a T_a from -50°C to $+40^{\circ}\text{C}$

T6: Temperature class of the transmitter (which corresponds to 85°C max) with a T_a from -50°C to $+40^{\circ}\text{C}$

About the applications, this transmitter can be used in “Zone 2” (Gas) and “Zone 22” (Dust) classified areas (unlikely/infrequent hazard) as it is shown on the following sketch:

Application for pressure transmitter Ex nL categories 3G and 3D

Application with Gas

Application with Dust

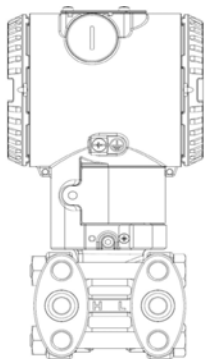

Zone 2

266 Tx Category 3G Ex nL

Note: the transmitter must be connected to a supply with 42V d.c. max output voltage as above indicated. The Ii of the transmitter is less than 25 mA.

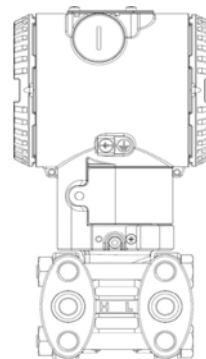

Zone 22

266 Tx Category 3D IP6x (Ex nL)

Note: the protection is mainly assured by the “IP” degree associated to the low power from supply.

i Important - Note for pressure transmitter with combined approval
Before installation of the Transmitter, the customer should permanent mark his chosen Protection Concept on the safety label. The transmitter can only be used with according to this Protection Concept for the whole life. If two or more types of protection box (on safety label) are permanent marked, the pressure transmitter must be removed from hazardous classified locations. The selected Type of Protection is allowed to be changed only by manufacturer after a new satisfactory assessment.

266 Models - HART

Entities for "L5" option integral LCD display (with TTG technology)

HART Version with "L5" option (display with TTG technology)

Ui= 30Vdc Ci= 5nF Li= uH

Temperature Class - Gas	Temperature Class - Dust	Minimum amb. °C	Maximum amb. °C	I _{max} mA	Power W
T4	T135°C	-50°C	+60°C	100	0,75
T4	T135°C	-50°C	+60°C	160	1
T5	T100°C	-50°C	+56°C	100	1,75
T6	T85°C	-50°C	+44°C	50	0,4

PROFIBUS Version with "L5" option (display with TTG technology)

Ui= 17,5 Vdc Ii= 360 mA Pi= 2,52 W Ci= 5nF Li= 10 uH

Temperature Class - Gas	Temperature Class - Dust	Minimum amb. °C	Maximum amb. °C
T4	T135°C	-50°C	+60°C
T5	T100°C	-50°C	+56°C
T6	T85°C	-50°C	+44°C

FIELDBUS / FISCO Version with "L5" option (display with TTG technology)

Ui= 17,5 Vdc Ii= 380 mA Pi= 5,32 W Ci= 5nF Li= 10 uH

Temperature Class - Gas	Temperature Class - Dust	Minimum amb. °C	Maximum amb. °C
T4	T135°C	-50°C	+60°C
T5	T100°C	-50°C	+56°C
T6	T85°C	-50°C	+44°C

Ex Safety aspects and IP Protection (North America)

According to FM Approvals Standards which can assure compliance with Essential Safety Requirements

FM 3600: Electrical Equipment for use in Hazardous (Classified) Locations, General Requirements.

FM 3610: Intrinsically Safe Apparatus and Associated Apparatus for Use in Class I, II, III, Division 1, and Class I, Zone 0 & 1 Hazardous (Classified) Locations.

FM 3611: Nonincendive Electrical Equipment for Use in Class I and II, Division 2 and Class III Division 1 and 2 Hazardous (Classified) Locations.

FM 3615: Explosionproof Electrical Equipment.

FM 3810: Electrical and Electronic Test, Measuring and Process Control Equipment.

NEMA 250: Enclosure for Electrical Equipment (1000 Volts Maximum)

The 2600T Series pressure transmitters have been certified by FM Approvals for the following Class, Divisions and Gas groups, hazardous classified locations, temperature class and types of protection.

- Explosionproof (US) for Class I, Division 1, Groups A, B, C and D, hazardous (classified) locations.
- Explosionproof (Canada) for Class I, Division 1, Groups B, C and D, hazardous (classified) locations.
- Dust Ignition proof for Class II, III Division 1, Groups E, F and G, hazardous (classified) locations.
- Suitable for Class II, III, Division 2, Groups F and G, hazardous (classified) locations.
- NonIncendive for Class I, Division 2, Groups A, B, C and D, in accordance with Nonincendive field wiring requirements for hazardous (classified) locations.
- Intrinsically Safe for use in Class I, II and III, Division 1, Groups A, B, C, D, E, F, and G in accordance with Entity requirements for hazardous (classified) locations.
- Temperature class T4 to T6 (dependent on the maximum input current and the maximum ambient temperature).
- Ambient Temperature range -40°C to +85°C (dependent on the maximum input current and the maximum temperature class).
- Electrical Supply range Minimum 10.5 Volts, Maximum 42 Volts (dependent on the type of protection, maximum ambient temperature, maximum temperature class and communication protocol).
- Type 4X applications Indoors/Outdoors.

For a correct installation in field of 2600T Series pressure transmitters please see the related control drawing.

Note that the associated apparatus must be FM approved.

Additional instruction for IEC61508 certified device (digits 8 or T under “output” options)

Safety philosophy

The 266 Pressure Transmitters are field devices designed according to the requirements of the standard IEC61508 for the Safety Related Systems. Standard currently used focus on individual parts of all the safe instrumentation used to implement a safety function. The IEC61508 defines requirements related to all the system that normally comprises initiating devices, logic solver and final elements. It also introduces the concept of Safety lifecycle defining the sequence of activities involved in the implementation of the safety instrumented system from conception through decommissioning. For a single component it is not correct to define a SIL level. The term SIL (Safety Integrity Level) refers to the complete safety loop therefore the single device shall be designed in order to be suitable to achieve the desired SIL level in the entire Safety Loop.

Application

The 266 Pressure Transmitters are intended to be applied for safety relevant application in the process industry. They are suitable to be used in SIL2 applications when applied as single channel and in SIL3 applications when applied with a double channel with architecture 1oo2. Special attention has to be given to the separation of safety and non safety relevant use.

Physical environment

The transmitters are designed for use in industrial field environments and must be operated within the specified environmental limits as indicated in the Transmitter Data Sheet.

Role and responsibilities

All the people, departments and organizations involved in the life-cycle phases which are responsible for carrying out and reviewing the applicable overall, E/E/PES (Electrical/Electronic/ Programmable Electronic System) or software safety lifecycle phases of a Safety Instrumented System shall be identified. All those specified as responsible for management of functional safety activities shall be informed of the responsibilities assigned to them. All persons involved in any overall, E/E/PES or software safety lifecycle activity, including management activities, should have the appropriate training, technical knowledge, experience and qualifications relevant to the specific duties they have to perform.

Management of functional safety

For each application the installer or the owner of a safety system must prepare a Safety Planning which must be updated throughout the Safety Life-cycle of the Safety Instrumented System. The safety planning shall include the Safety instrumentation management.

The requirements for the management of functional safety shall run in parallel with the overall safety lifecycle phases. Safety Planning.

The Safety Planning shall consider:

- policies and strategies for achieving safety;
- safety life-cycle activities to be applied, including names of responsible persons and departments;
- procedures relevant to the various life-cycle phases;
- audits and procedures for follow up.

Information requirements (to be made available by the plant owner)

The information shall comprehensively describe the system installation and its use in order that all phases of the overall safety lifecycles, the management of functional safety, verification and the functional safety assessment can be effectively performed.

Overall safety life-cycle information

The overall safety lifecycle shall be used as the basis for claiming conformance to the standard IEC61508. The lifecycle phases consider all the activities related to the Safety Instrumented System (SIS) from the initial concept through design, implementation, operation and maintenance to decommissioning.

Applicable laws and standards

All applicable general Laws and Standards related to the allowed operations of the equipment, as EU-Directives shall be collected. The plant owner shall produce a Regulatory Requirements List document.

266 Models - HART

System safety requirement assignment I/O system response time

The total system response time is determined by the following elements:

- Sensor detection time,
- Logic solver time;
- Actuator response time;

The total system response time must be less than the process safety time. To ensure a safe operation of the system, the scan rate of each section of the logic solver multiplied by the number of channels shall be taken into account together with the safety time of actuator and sensor response time.

System structure

System configuration drawings shall be available to describe the equipment and interfaces required for a complete operational system. The system must be fully operational before start-up.

Safety requirement allocation

Each safety function, with its associated safety integrity requirement, shall be allocated to the designated safety related systems taking into account the risk reductions achieved by the other technology safety-related systems and external risk reduction facilities, so the necessary risk reduction for that safety function is achieved.

The allocation indicated shall be done in such a way that all safety functions are allocated and the safety integrity requirements are met for each safety function.

Safety routines

Safety additional requirements may be defined in order to ensure the correct functionality of sequences in the Safety Instrumented System.

Commissioning

Overall system functionality

The activity to validate the required safety functionality of the system together with the pressure transmitter according to the Safety Requirement Specification is the Pre-Startup Acceptance test.

Faults outside the functional safety

The redundant algorithms and the electronics are designed to detect all the internal hardware faults therefore the transmitter diagnostic is not able to detect faults related to the process and to the installation configuration. In the following table the known weaknesses resulting from the transducer FMEA (Failure Mode and Effect Analysis) are listed.

- Assembled material at the pipes of the transmitter, blockage of pipe.
- Application outside specified temperature range.
- Excess of temperature
- Assembled gas at the transmitter, if the transmitter is mounted above the process line
- Overload pressure, high peak pressure pulses in process lines
- Penetration of hydrogen, diaphragm crack in applications with hydrogen process medium.
- Thin walled diaphragm, leaky diaphragm in applications with abrasive medium.
- Thin walled diaphragm, leaky diaphragm in applications with corrosive medium.
- Higher diaphragm stiffness, crack in application with contamination of metal ions
- Mechanical damage through cleaning, damage of the coating, corrosion.

Other considerations

The alarm levels of the transmitter (down-scale or up-scale) can be selected by the user. As default all the 266 devices are configured with up-scale alarm. For some faults (e.g. crystal breakdown), the output will latch at 3.6 mA even if the up scale alarm level is selected.

Architecture description and principle of operation

The instrument consists of two main functional units:

- Primary unit
- Secondary unit

The pressure transducer unit includes the process interface, the sensor and the front-end electronics; the Secondary Unit includes the electronics, the terminal block and the housing. The two units are mechanically coupled by a threaded joint.

Principle of operation

The principle of operation is as follows. In the primary unit the process fluid (liquid, gas or vapour) exerts pressure on to the sensor via flexible, corrosion-resistant isolating diaphragms and capillary tubing containing the fill fluid.

As the sensor detects the pressure changes, it simultaneously produces variations of the primary physical value depending on the sensor technology (capacitive, inductive or piezoresistive). The signal is then converted in the front-end electronics in a digital form and the raw values are computed by a microcontroller to a precise primary output linearization, compensating for the combined effects of sensor non linearity, of static pressure and temperature changes on the basis of the “mapped” parameters calculate in the manufacturing process and stored in the memory of the Front End electronics. Calculations follow independent flows and they are compared in the microcontroller in order to validate the output pressure signal. If a difference between the two measurements is detected the analog output is driven to a safety condition. The measured values and the sensor parameters are transferred via a standard serial digital communication to the secondary unit where the communication board is fitted.

The output data value is converted into a pulse-width signal that is filtered and that activates the 4-20 mA transmitter.

The bi-directional, digital communication using the standard “HART” protocol is implemented as part of this unit. Internal diagnostics algorithms are implemented to check correctness and validity of all processing variables and the correct working of memories. The output stage is also checked by reading back the analog output signal and by reading the power supply voltage. The feedback loop is obtained by an additional A/D converter put at the end of the output stage, which translates the 4-20 mA signal into a digital form suitable to be compared by the microcontroller.

Commissioning and configuration issues

The transmitter is considered in safety condition (normal operating mode) when the write protect switch placed outside the transmitter housing below the metallic nameplate is in Write Protect. In that condition all kind of configurations of the device are disabled.

Operating mode enabling and disabling

Operating mode can be enabled/disabled depending on the switch position. It is also possible to put the device in write protect condition by a dedicated HART command. In any case the switch position has the priority on the software command.



Warning

After any configuration operation, the transmitter must be put in operating mode

Proof tests

Safe undetected faults could occur during the operation of the transmitters. These failures do not affect the transmitter operations. To maintain the claimed Safety Integrity Level (SIL 2) a proof test procedure is requested every 10 years.

The proof tests consist in the following operations:

- Switch off the device.
- Assure that the Write Protect Mode switch is in Write Protect condition.
- Power-on the transmitter: the transmitter performs automatically a self-test that consists in the operations below:

ROM test

RAM test

Test of the analog output stage and of the feedback A/D converter

Test of the power supply voltage

Non volatile memory test

- Apply pressure up to 50% of the calibrated range and check the output value. It shall be within the stated safety accuracy (2% of sensor range).

266 Models - HART

In case the tests would fail the transmitter will drive the output to the alarm values. In this case a correction action consists in the re-calibration of the D/A converter. In case the normal functionality will be not re-established, the transmitter shall be considered failed and not possible to use.

Safety-related parameters

The Safety 266 pressure transmitters product meets the SIL2 requirements of IEC 61508 in low as well as high demand mode of operation. The total PFD in low demand mode for 10 years proof test interval in the worst case is less than the 15% of the range defined in IEC 61508-1. The relevant numbers are stated in the table below:

	266DXX, 266VXX, 266PXX, 266HXX, 266NXX	266MXX, 266CXX, 266JXX, 266RXX (range R)	266MXX, 266CXX, 266JXX, 266RXX (except range R)	266GXX, 266AXX (except range C and F)	266GXX, 266AXX (only range C and F)
λ_{dd}	2,62E-07	4,11E-07	3,94E-07	4,05E-07	4,13E-07
λ_{du}	6,82E-08	6,87E-08	6,85E-08	6,85E-08	6,90E-08
λ_{sd}	3,37E-07	2,45E-07	2,39E-07	2,40E-07	2,40E-07
λ_{su}	3,01E-07	3,55E-07	3,53E-07	3,42E-07	3,18E-07
HFT	-	-	-	-	-
T1	1 year / 10 years (8760h / 87600h)				
SFF	92,95%	93,63%	93,51%	93,51%	93,37%
Total Failure Rate	9,68E-07	1,08E-06	1,06E-06	1,06E-06	1,04E-06
MTBF	118	106	108	108	110
MTTR	8 hours				
DC	D: 79%	D: 86%	D: 85%	D: 86%	D: 86%
	C: 53%	C: 41%	C: 40%	C: 41%	C: 43%
PFD (1 year)	2,99E-04	3,01E-04	3,00E-04	3,00E-04	3,02E-04
PFH (1 year)	6,82E-08	6,87E-08	6,85E-08	6,85E-08	6,90E-08
PFD (10 years)	2,98E-03	3,00E-03	2,99E-03	2,99E-03	3,01E-03
PFH (10 years)	6,82E-08	6,87E-08	6,85E-08	6,85E-08	6,90E-08
Testing time	< 20 s	< 20 s	< 20 s	< 5 s	< 70 s
ROM check time	< 30 s	< 30 s	< 30 s	< 30 s	< 70 s



RETURN REPORT – No.: _____

*) Please always fill in. Otherwise the case will not be handled as return

CONTROL OF SUBSTANCES HAZARDOUS TO HEALTH (C.O.S.H.H.)

Decontamination declaration - EQUIPMENT RETURNED FOR REPAIR, CALIBRATION OR CREDIT

From _____

Description _____

Return authorization no. _____

Model number _____

Serial number _____

- | | |
|----|--|
| A) | <i>The above equipment has not been in contact with any material which is hazardous to health.</i> |
| B) | <i>The above equipment has been in contact with the material(s) noted below but that it has now been completely de-contaminated and is now safe to handle and dismantle without any special precautions. Material(s) which have been in contact with this equipment:</i> |
| C) | <i>If A) or B) are not applicable full instructions for the safe handling of this equipment for disposal must be supplied.</i> |

Please delete A), B) or C) above as applicable, complete the signature section below, then send the completed declaration either with the returned items, or by fax for the attention of the Calibration & Repair Centre..
Note – no action to examine or repair equipment will be undertaken until a valid COSHH declaration has been received, completed by an authorized officer of the end user company.

Signed _____

Name _____

Position _____

Date _____

ABB S.p.A
Process Automation Division
Uffici Commerciali / Sales Office:
Via Statale, 113 - 22016 Lenno (CO) Italy
Tel. +39 0344 58 111
Fax +39 0344 56 278
e-mail: abb.instrumentation@it.abb.com



EC DECLARATION OF CONFORMITY

EG-KONFORMITÄTSERKLÄRUNG
ATTESTATION DE CONFORMITE CE

Manufacturer: <i>Hersteller / Fabricant:</i>	ABB Automation Products GmbH Minden	Manufacturer: <i>Hersteller / Fabricant:</i>	ABB SpA
Address: <i>Anschrift / Adresse:</i>	Schillerstraße 72 D-32425 Minden	Address: <i>Anschrift / Adresse:</i>	Via Statale 113 I-22016 Lenno (Co)
Product name: <i>Produktbezeichnung: Désignation du produit:</i>	Pressure Transmitter - 266 Druck-Messumformer – 266 Transmetteur de Pression – 266	Product name: <i>Produktbezeichnung: Désignation du produit:</i>	Pressure Transmitter - 266 Druck-Messumformer – 266 Transmetteur de Pression – 266

This product meets the requirements of the following European directives:

Das Produkt stimmt mit den Vorschriften folgender Europäischer Richtlinien überein:

Les produits répondent aux exigences des Directives C.E. suivantes:

2004/108/EC Electromagnetic Compatibility Directive *

*EMV-Richtlinie **

*Directives concernant la compatibilité électromagnétique **

2006/95/EC EC-Low-Voltage Directive *

*Niederspannungsrichtlinie**

*Directives concernant la basse tension **

*** including alterations and German realization by the EMC law and the instruments safety law**

** einschließlich Änderungen und deutscher Umsetzung durch das EMVG und Gerätesicherheitsgesetz*

** y compris les modifications et la réalisation allemande par la loi concernant la compatibilité électromagnétique et la sécurité d'appareils*

Conformity with the requirements of these Directives is proven by complete adherence to the following standards:

Die Übereinstimmung mit den Vorschriften dieser Richtlinien wird nachgewiesen durch die vollständige Einhaltung folgender Normen:

La conformité avec les exigences de ces directives est prouvée par l'observation complète des normes suivantes:

EN 61 000-6-1 / EN 61 000-6-2 / EN 61 000-6-3 / EN 61 000-6-4 / EN 61 010-1

97/23/EC Pressure Equipment Directive, Category III Module H (for pressure PS > 200 bar)

Druckgeräterichtlinie, Kategorie III Modul H

(für Druck PS > 200bar)

Directive Equipements sous Pression, Catégorie III Module H (pour pression PS > 200 bar)

CE 0045 For Minden Manufacturer

CE 0474 For Lenno Manufacturer

Pressure/druck/Pression PS ≤ 200bar: SEP

For products in Ex design according to identification on nameplate the following is additionally applicable:

Für Geräte in Ex-Ausführung gemäß Kennzeichnung auf Typschild gilt zusätzlich:

Pour des produits en exécution Ex selon marque sur plaque signalétique le suivant est aussi applicable :



94/9/EC ATEX-Directive

ATEX Richtlinie

ATEX Directive

Ex: The standards of the relevant type-examination certificates shall apply

Es gelten die Normen der entsprechenden EG-Baumusterprüfbescheinigungen

Il convient d'appliquer les normes des certificats d'homologation CE

Date: 27.10.2010

Wolfgang Scholz
Leiter R&D
Head of R&D
Responsable R&D

Manfred Klüppel
Leiter Qualitätssicherung
Head of Quality Assurance
Responsable Assurance de la Qualité

Eugenio Volonterio
Leiter R&D
Head of R&D
Responsable R&D

Walter Volo
Leiter der Verwaltung Zertifizierungen
Head of Certifications Management
Responsable de la gestion Certifications

ABB Automation Products GmbH

ABB SpA

EG-Konformität_266_27_ott_2010_A.doc

266 Models - HART

Contact us

To find your local ABB contact visit:

www.abb.com/contacts

For more product information visit:

www.abb.com

Note

We reserve the right to make technical changes or modify the contents of this document without prior notice. With regard to purchase orders, the agreed particulars shall prevail. ABB does not accept any responsibility whatsoever for potential errors or possible lack of information in this document.

We reserve all rights in this document and in the subject matter and illustrations contained therein. Any reproduction, disclosure to third parties or utilization of its contents - in whole or in parts - is forbidden without prior written consent of ABB.

Copyright© 2011 ABB
All rights reserved

™ Viton is a Dupont de Nemour trademark
™ Kynar is an Elf Atochem North America Inc trademark

OI/266/HART-EN Rev.E 03.2011 | 3KXP000002R4201